

**NUMERICAL CAPACITOR BANK PROTECTION RELAY
ANC 214/ 402/ 033 [AN SERIES]**

User Manual



**ALUMINIUM INDUSTRIES LIMITED
RELAYS DIVISION
THIRUVANANTHAPURAM**

ANC 214/ 402/ 033

Numerical Capacitor Bank Protection Relay

CONTENTS

SAFETY REQUIREMENTS	ANC 214/ 402/ 033-I
<hr/>	
INTRODUCTION	ANC 214/ 402/ 033-II
<hr/>	
HANDLING INSTALLATIONS & CASE DIMENSIONS	ANC 214/ 402/ 033-III
<hr/>	
USER GUIDE	ANC 214/ 402/ 033-IV
<hr/>	
TECHNICAL DATA & CHARACTERISTIC CURVES	ANC 214/ 402/ 033-V
<hr/>	
TROUBLE SHOOTING	ANC 214/ 402/ 033-VI
<hr/>	
COMMUNICATION	ANC 214/ 402/ 033-VII
<hr/>	

SAFETY REQUIREMENTS



CONTENTS

INTRODUCTION

HEALTH AND SAFETY

SYMBOLS AND EXTERNAL LABELS ON THE RELAY

INSTALLING, COMMISSIONING AND SERVICING

DECOMMISSIONING AND DISPOSAL

TECHNICAL SPECIFICATION FOR SAFETY



INTRODUCTION

Before using this product, be sure to read this chapter carefully.

This chapter describes safety precautions when using the relay. Before installing and using the equipment, read and understand this chapter thoroughly.

It's not a secret – electricity can be dangerous and when things go wrong lives can be at stake!

Electrical engineers are Industrial safety doctors, so it's our duty to keep employees health and maintain a quality of life that we all deserve by providing safe work practices to avoid electrical accidents.

How much electricity is dangerous?????

CURRENT	EFFECT
0.5 – 3mA	Tingling sensations
3 – 10mA	Muscle contractions (painful)
10 – 40mA	"can't let go" phenomena
40 – 75mA	Respiratory paralysis (possibly fatal)
75 – 200mA	Ventricular fibrillation (likely fatal)
200 – 500mA	Heart clamps tight
>1.5A	Tissue and organs began to burn

Fact: A 15 amp circuit breaker was designed to protect equipment – not people!

The relay is developed with zero percentage of risk factor by its own design. The current carrying paths and circuits are isolated from the metal case and structure. Suitable clearance depending on the type of insulation required for different classes are provided.

The relay confirms to Product safety requirement standard IEC 60255-27.



HEALTH AND SAFETY

It deals with the handling of relay in proper way. An individual to be considered as 'qualified' with regard to certain equipment in the workplace, but 'unqualified' as to other equipment. "An employee, who is undergoing on the job training and who, in the course of such training, has demonstrated the ability to perform duties safely at his or her level of training and who is under the direct supervision of a qualified person also considered to be a qualified person for the performance of those duties."

The following requirements must be met, in the order given, before circuits or equipments are re-energized, even temporarily.

- ✚ People handling the equipment should be aware about the relay safety handlet.
- ✚ Ensure that the product is in the off condition before working on the conducting or terminal side.
- ✚ A qualified person must conduct tests and visual inspections, as necessary, to verify that tools electrical jumpers, shorts, grounds and other such devices have been removed, so that the circuits and equipments can be safely re-energized.
- ✚ Employees exposed to the hazards associated with re-energizing the circuit or equipment must be warned to stay clear of the circuits and equipment.
- ✚ Each lock and tag must be removed by the employee who applied it or someone else under that employee's direct supervision.
- ✚ A visual determination that all employees are clear of the circuits and equipments must be made.

For any queries related to relays, feel free to contact ALIND.



SYMBOLS AND LABELS USED IN THE RELAY

1. FRONT SIDE



Caution: refer to equipment documentation



Caution: risk of electric shock

2. REAR SIDE



WARNING

1. No user serviceable components inside.
2. Refer servicing to authorized personnel.



Protective Conductor (*Earth) terminal

Functional/Protective Conductor (*Earth) terminal.

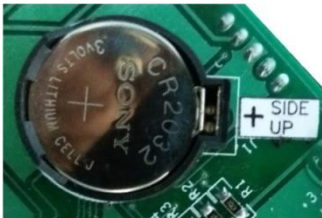

CMOS Battery provided for the RTC (Real Time Clock) purpose. Confirm polarity of the battery while replacing.

WARNING**Current transformer circuit**

Never allow the current transformer (CT) secondary circuit connected to this equipment to be opened while the primary system is live. Opening the CT circuit will produce a dangerous high voltage.

**Exposed terminals**

Do not touch the terminals of this equipment while the power is on, as the high voltage generated is dangerous.

**Residual voltage**

Hazardous voltage can be present in the DC circuit just after switching off the DC power supply. It takes about 30 seconds for the voltage to discharge.

CAUTION**Earth**

Earth the earthing terminal of the equipment securely.

**Operation conditions**

Use the equipment within the range of ambient temperature, humidity and dust as detailed in the specification and in an environment free of abnormal vibration.

**Ratings**

Before applying AC voltage and current or DC power supply to the equipment, check that they conform to the equipment ratings.

**Printed circuit board**

Do not attach and remove the printed circuit board while the DC power to the equipment is on, as this may cause the equipment to malfunction.

**External circuit**

When connecting the output contacts of the equipment to an external circuit, carefully check the supply voltage used and prevent the connected circuit from overheating.

**Connection cable**

Carefully handle the connection cable without applying excessive force.



Modification

Do not modify this equipment, as this may cause the equipment to malfunction, and in any such cases, warranty may be affected.

DECOMMISSIONING AND DISPOSAL



De-commissioning

The supply input (auxiliary) for the equipment may include capacitors across the supply or to earth. To avoid electric shock or energy hazards, after completely isolating the supplies to the equipment, the capacitors should be safely discharged via the external terminals prior to de-commissioning.



Disposal

When disposing of this equipment, do so in a safe manner according to local regulations. It is recommended that incineration and disposal to water courses is avoided. Ensure the relay is in de energized condition and take precautions to avoid short circuits.

TECHNICAL SPECIFICATIONS FOR SAFETY

1. Protective class

IEC 60255-27:2005	Class I	(This equipment requires a protective conductor (earth) connection to ensure user safety.)
-------------------	---------	--

2. Environment

IEC 60255-27:2005	Pollution degree 2	(Normally only non-conductive pollution occurs except occasionally a temporary conductivity caused by condensation is to be expected.)
-------------------	--------------------	--

3. Overvoltage Category

IEC 60255-27:2005	Category III	(The auxiliary energizing circuits of the equipment are connected to a common battery, common mode transient voltages of a relatively high value may appear on the supply leads, and differential mode voltages may arise from switching in other circuits connected to the same battery source.)
-------------------	--------------	---

4. Contact data

Test voltage across open contact: 1 kV DC for 1 min source.



INTRODUCTION



CONTENTS

AN SERIES DESCRIPTION

PREVIOUS HISTORY OF CAPACITOR BANK PROTECTION RELAYS

BRIEF DESCRIPTION OF ANC 214/ 402/ 033

MAIN FUNCTIONS

GENERAL FUNCTIONS



AN SERIES (ALIND NUMERICAL SERIES)

- Advanced Digital Fourier Transform based Numerical algorithm design using 16-bit Digital Signal Controller (DSC).
- Compact Construction covering several protection modules saving panel space.
- Man-Machine Communication through 20x4 character LCD display and LEDs.
- Self supervision of both hardware and software units.
- Interface ability with SCADA is achieved through IEC 60870-5-103 communication protocol.
- Facility for storing fault waveforms (Disturbance recorder) and events with date and Time stamping. At a time a total of 5000 events and 200 latest fault waveforms (Disturbance recorder) will be stored in the relay.
- Graphical User Interface for Harmonic analysis, DC analysis and di/dt analysis can be done on the uploaded fault waveforms with facility for report generation.
- Facility to access/modify the relay settings both online as well as through menu in local PC through SCADA at RCC.
- Relay Indication (LED) reset from RCC.
- Suitable password protection.
- IP 54 grade enclosure protection.
- GPS time Synchronization Facility.
- Settable CT and PT ratios.
- CB close and open command initiation from relay through RCC.

PREVIOUS HISTORY OF CAPACITOR BANK RELAYS

AFC 204

Numerical Capacitor Bank relay

Disturbance & event recorder.

Built in counter facility.

ANC 214/ 402/ 033

The relay is the modified version of our AFC 204 (AN Series) relay.

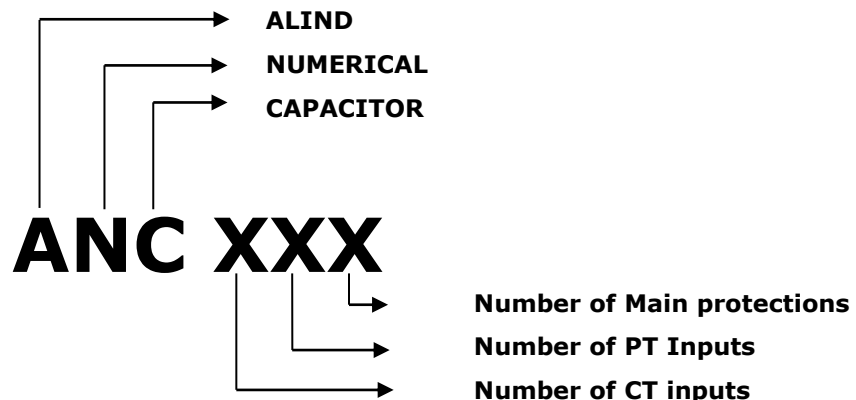

ANC 214:

The relay conforms to RDSO specification No. TI/SPC/PSI/PROTCT/6071. ANC 214 (AN Series) relay is a comprehensive Integrated Capacitor Bank Protection relay for the protection of conventional 27 KV AC single phase, 50Hz Over Head Equipment (OHE).



ANC 402/ 033:

The relay conforms to RDSO specification No. TI/SPC/PSI/PROTCT/7100(07/2012). ANC 402/ 033 (AN Series) relay is a comprehensive Integrated Feeder Protection relay for the protection of 2x 25 KV (AT feeding system) AC single phase, 50Hz Over Head Equipment (OHE).

MAIN FUNCTIONS

SI No.	PARTICULARS	ANC 214	ANC 402	ANC 033
1.	MAIN PROTECTIONS			
1.1	IDMT OC Protection	✓	✓	
1.2	Over Voltage Protection	✓		✓
1.3	Under Voltage Protection	✓		✓
1.4	Unbalance Protection	✓	✓	✓
1.5	Time Delay Relay	✓	✓	✓
1.6	LBB	✓	✓	✓
1.7	Relay Fail	✓	✓	✓
2.	STATUS INPUTS			
2.1	AP/GP LOW ALARM	✓	✓	
2.2	AP/GP LOW TRIP & LOCK	✓	✓	
2.3	BRKR STATUS NC	✓	✓	✓
2.4	BRKR STATUS NO	✓	✓	✓
2.5	RCC RESET	✓	✓	✓
2.6	TIME SYNC	✓	✓	✓
2.7	UNBALANCE RESET	✓	✓	✓

GENERAL FUNCTIONS

SI No.	PARTICULARS	ANC 214
1.	Password protection	✓
2.	Event Memory	5000
3.	Disturbance recorder waveforms	200
4.	50 cycles (45 pre and 5 post fault) of fault waveform	✓
5.	COMMUNICATION	
5.1	GUI Interface	Mini USB
5.2	Isolated RS 485 Interface	✓
5.3	Communication Protocol Interface- IEC 60870-5-103	✓
5.4	GPS Time Sync Facility	✓
5.5	Date/time synchronization through PC	✓
5.6	Relay programming through Mini USB port	✓
6.	MONITORING	
6.1	Line Current (IDMT)-ANC 214 & ANC 402	✓
6.2	Unbalance Current-ANC 214 & ANC 402	✓
6.3	Under Voltage-ANC 214 & ANC 033	✓
6.4	Over Voltage-ANC 214 & ANC 033	✓
6.5	Counters for each element (IDMT, UB, UV, OV)	✓
7.	USER INTERFACE	
7.1	Test facility in Relay setting Mode (offline)	✓
7.2	Compact Module	✓
7.3	Plug In Type	✓



HANDLING INSTALLATIONS & CASE DIMENSIONS



CONTENTS

HANDLING OF RELAY

STORAGE

RELAY AND RACK MOUNTING

CASE DIMENSIONS



HANDLING OF RELAY

Protective relays generally of robust construction require careful treatment prior to installation on site. Care must be taken when unpacking and installing the relays so that none of the parts are damaged. Relays must be handled by skilled personnel. The following should be taken into account while handling the relay:

- ✚ The relay use components that are sensitive to electrostatic discharges. The relay comprises of various semi-conductor devices which can damage if touched by means of direct contact. Handle the cards in static free environment since electrostatic discharge can affect performance of the relay or cause damage to the cards.
- ✚ The electronic circuits are well protected by the metal case and the internal module should not be withdrawn unnecessarily.
- ✚ The relay is normally shipped in separately packed condition. After unpacking, see if there is any mechanical damage to the cabinet, the nameplate, terminal blocks etc. Damage of any such sort identified shall be intimated to works.
- ✚ Avoid plugging in/ pulling out the cards when the power is ON.
- ✚ Do not apply CT inputs when auxiliary supply is switched OFF.
- ✚ If the cards are withdrawn for testing, ensure proper positioning while replacing.
- ✚ Keep the relays in well-packed condition in a dust-free dry environment without direct exposure to sunlight.

The relay is shipped from factory after detailed testing by our Quality Control Department. However, according to the customer requirement the relay settings/ functions can be verified before commissioning at respective sites with proper testing kits.

STORAGE

If relays are not to be installed immediately upon receipt they should be stored in a place free from dust and moisture in their original boxes. At most care should be taken while storage.

Storage temperature: -25°C to +70°C.



RELAY AND RACK MOUNTING

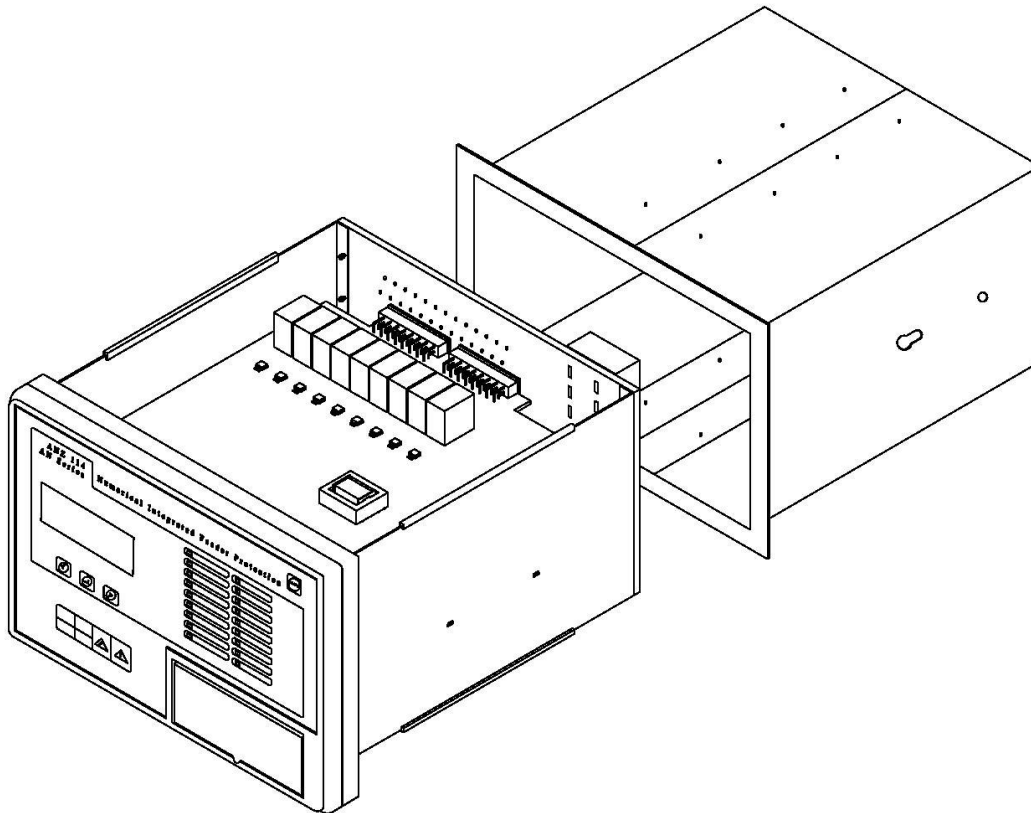

CASE DIMENSIONS

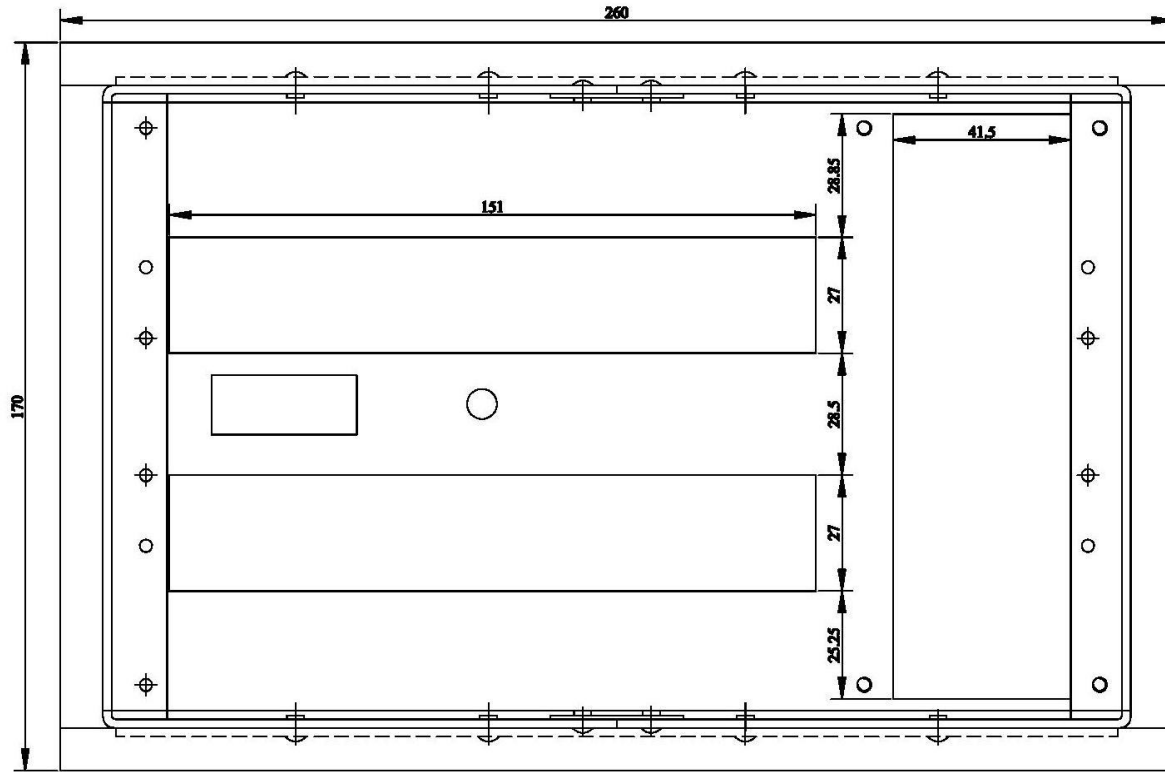

⊕ 8 Holes for Rivet ○ 4 Holes Ø4



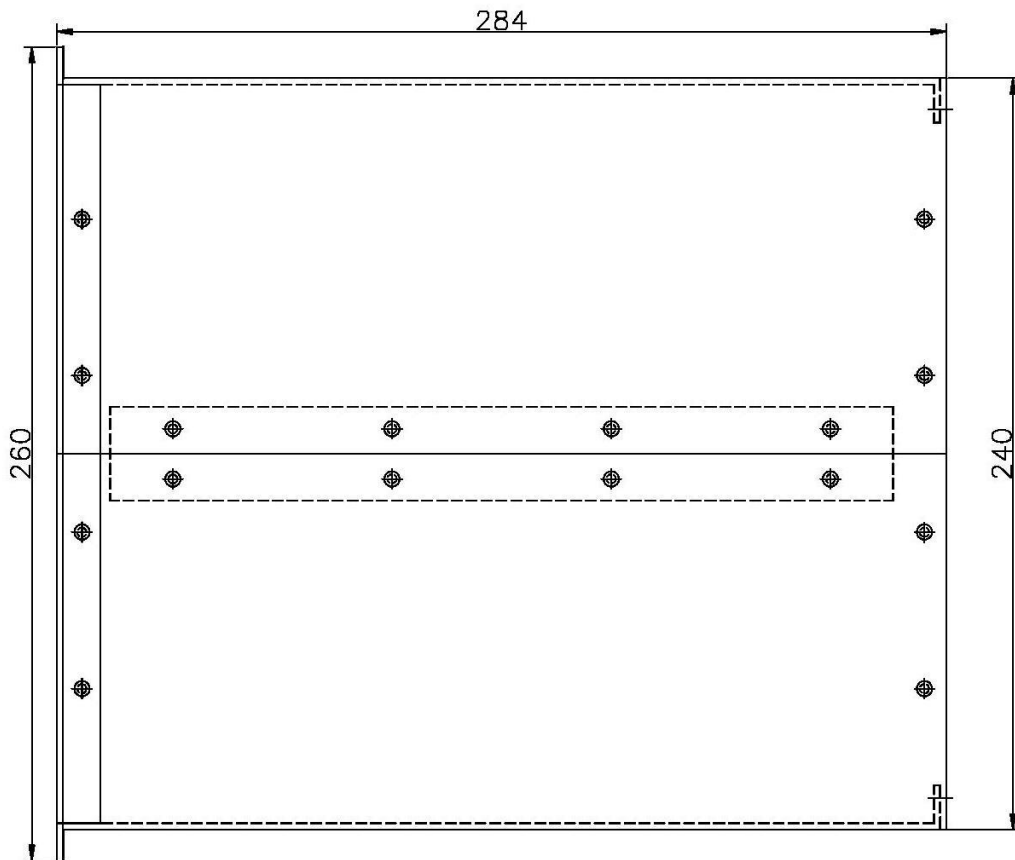
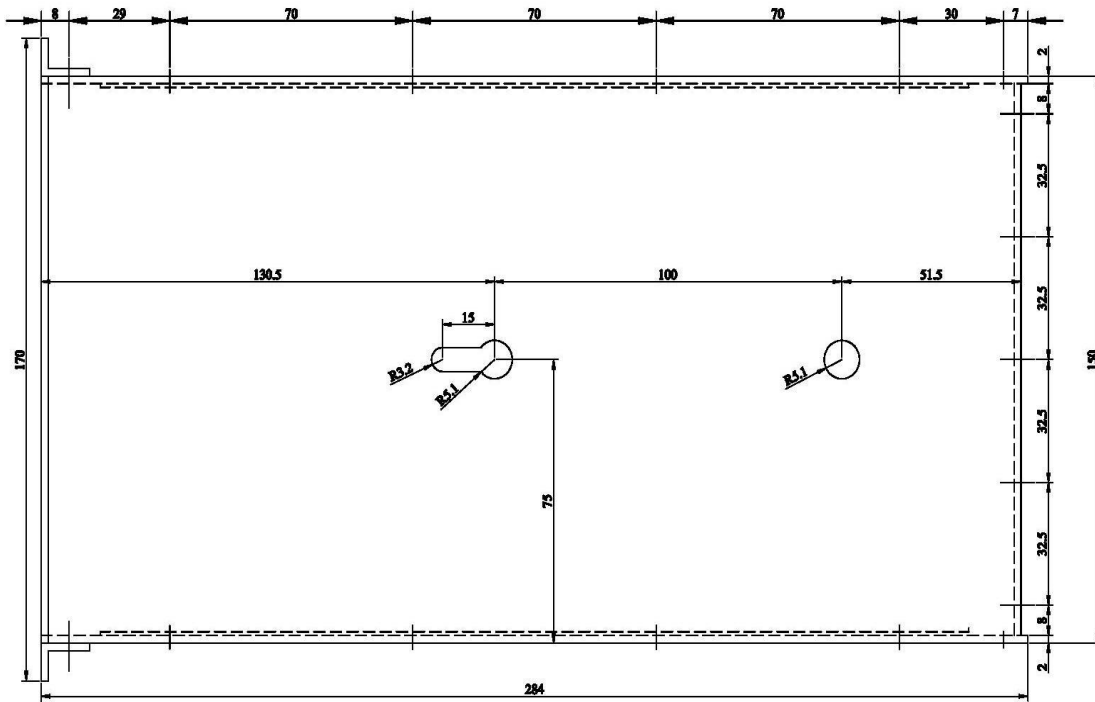

TOP VIEW



USER GUIDE



CONTENTS

FRONT PANEL INDICATIONS

INTERNAL ARCHITECTURE AND BLOCK DIAGRAM

ENERGIZING THE RELAY

PCB DESCRIPTION

RELAY SETTINGS AND ALGORITHM



FRONT PANEL INDICATIONS

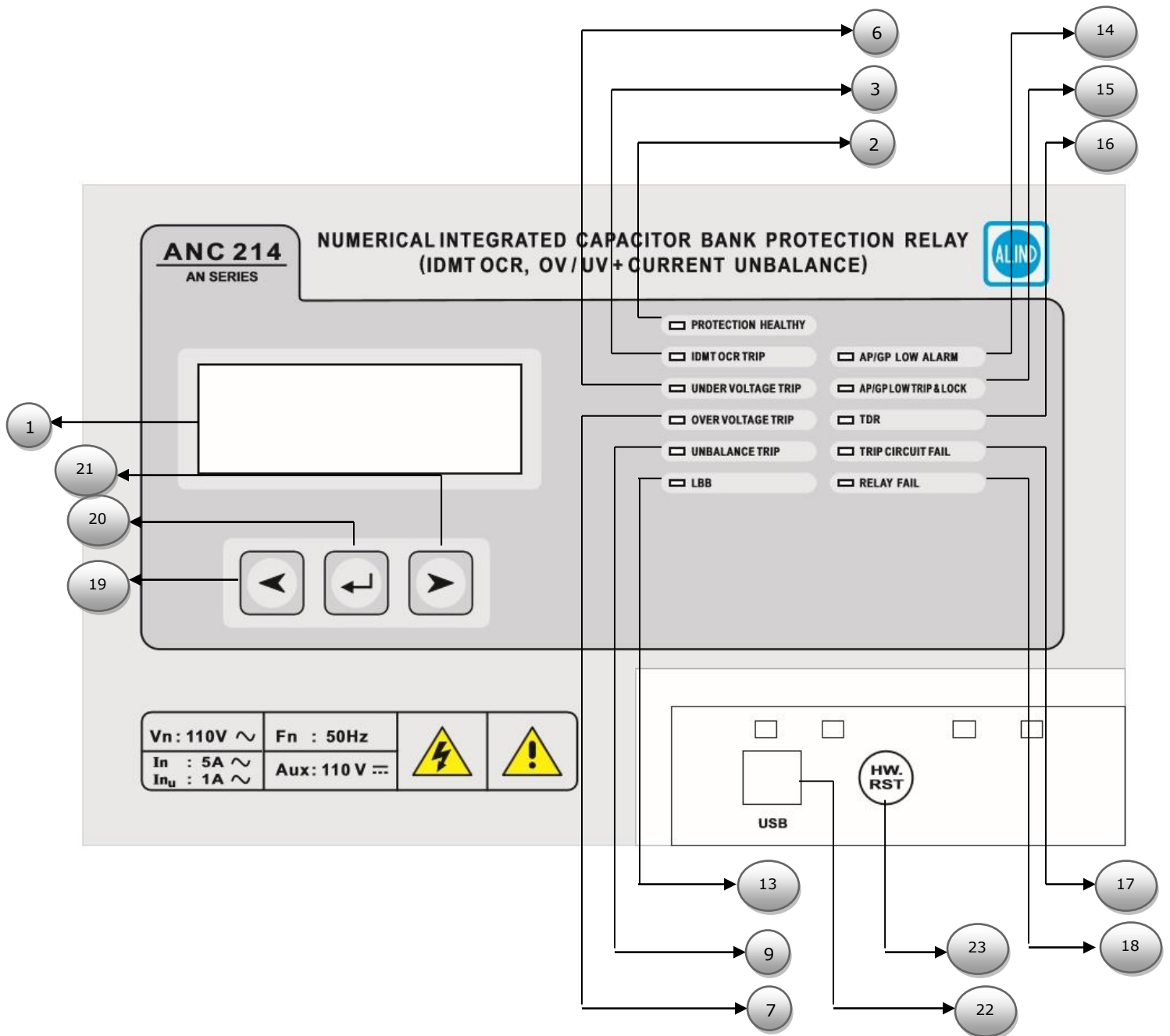

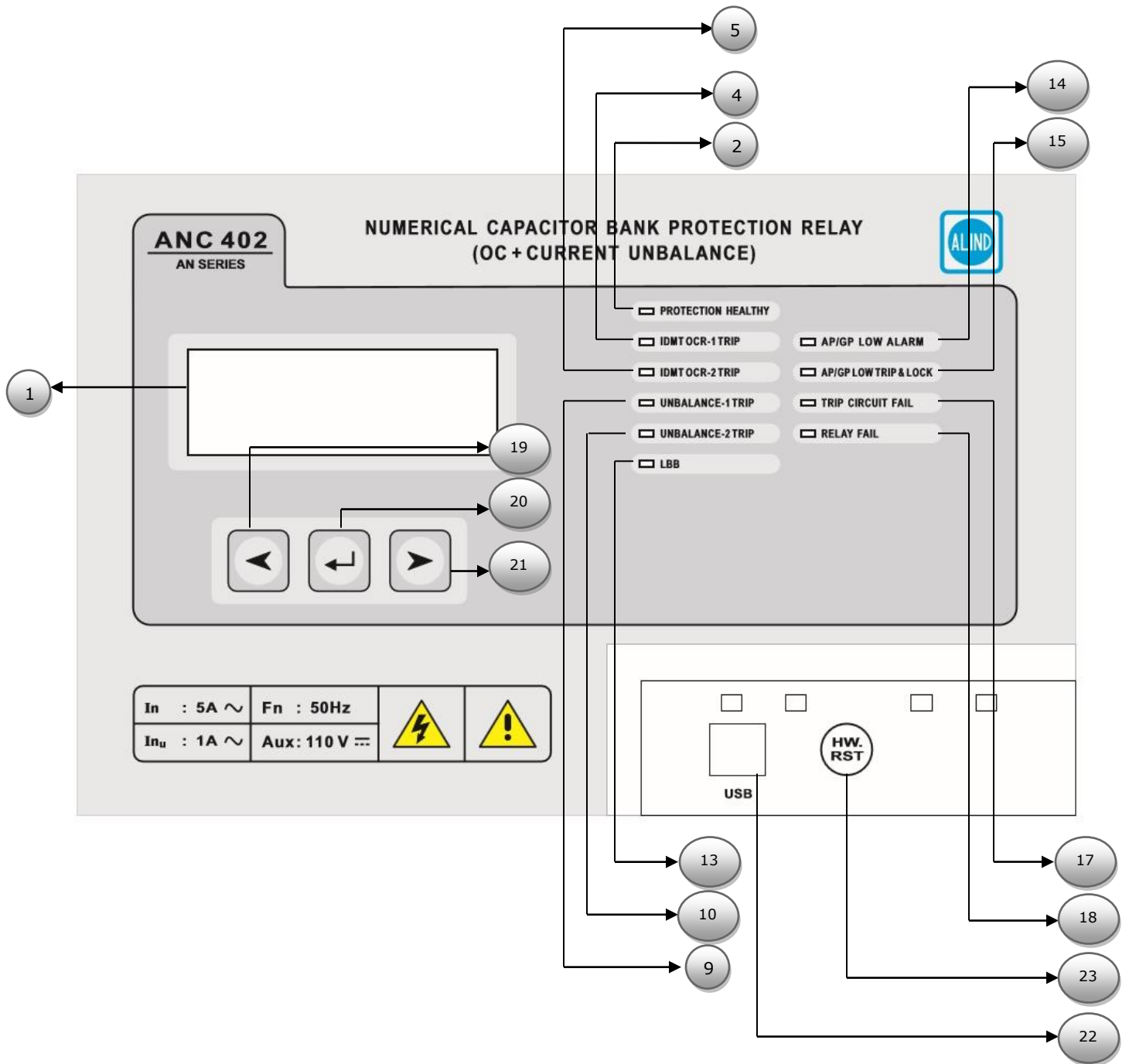

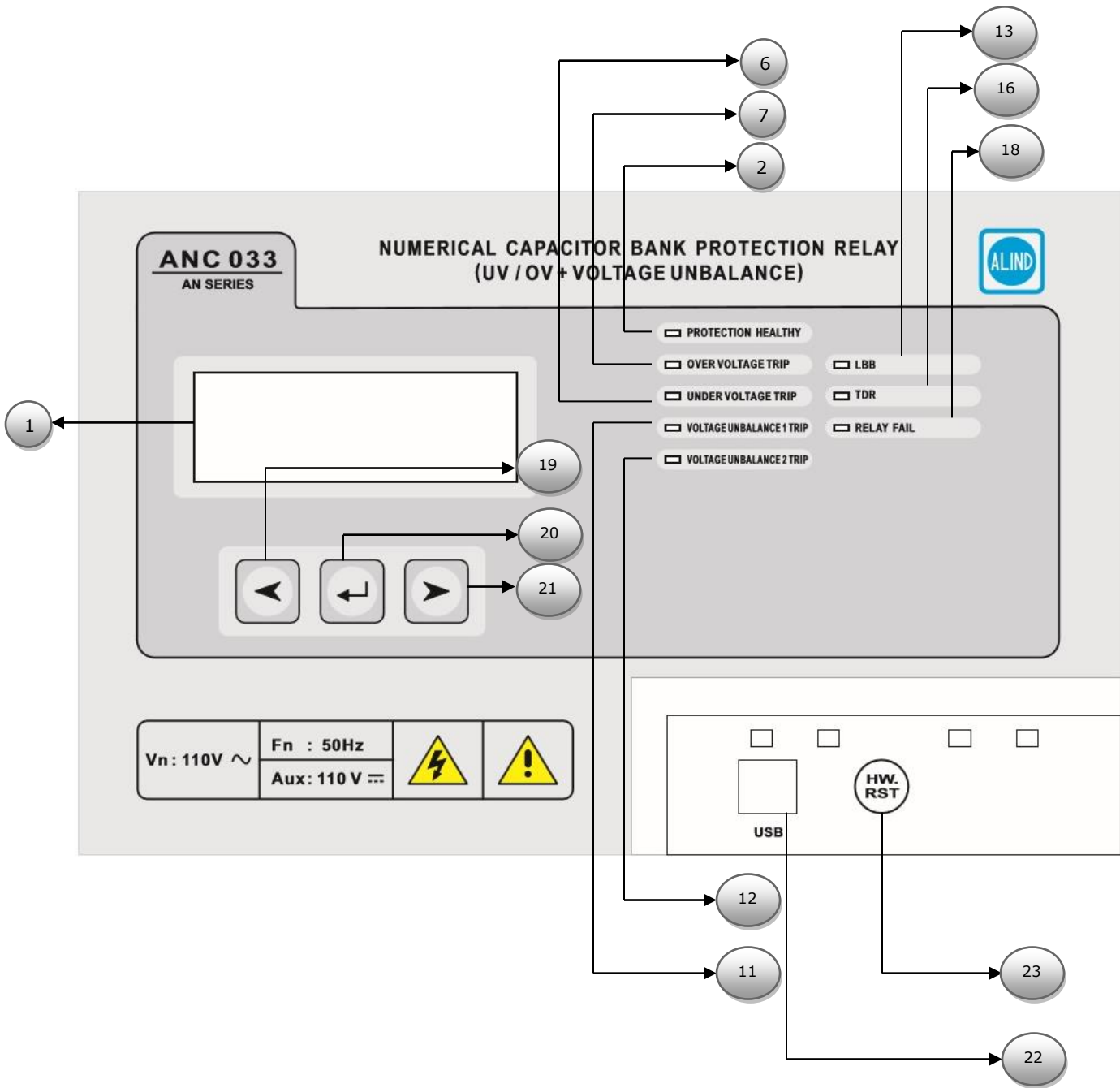

No	Legend	ANC 214	ANC 402	ANC 033
1.	LCD DISPLAY	✓	✓	✓
2.	PROTECTION HEALTHY (Green/Amber)	✓	✓	✓
3.	IDMT OCR TRIP (Red)	✓		
4.	IDMT OCR-1 TRIP (Red)		✓	
5.	IDMT OCR-2 TRIP (Red)		✓	
6.	UNDER VOLTAGE TRIP (Red)	✓		✓
7.	OVER VOLTAGE TRIP (RED)	✓		✓
8.	UNBALANCE TRIP (RED)	✓		
9.	UNBALANCE-1 TRIP (RED)		✓	
10.	UNBALANCE-2 TRIP (RED)		✓	
11.	VOLTAGE UNBALANCE1 TRIP			✓
12.	VOLTAGE UNBALANCE2 TRIP			✓
13.	LBB (Red)	✓	✓	✓
14.	AP/GP LOW ALARM (Red)	✓	✓	
15.	AP/GP LOW TRIP & LOCK (Red)	✓	✓	
16.	TDR(Red)	✓		✓
17.	TRIP CIRCUIT FAIL	✓	✓	
18.	RELAY FAIL	✓	✓	✓
19.	>	✓	✓	✓
20.	↵	✓	✓	✓
21.	<	✓	✓	✓
22.	USB	✓	✓	✓
23.	H.RST	✓	✓	✓

LCD DISPLAY

A 20 x 4 LCD display is provided for easy viewing of parameters, relay settings, fault event records, date& time, error counter etc. The display backlit can be made ON by pressing any push button key except H.Rst key and the display backlit leaves for about 20 seconds. Backlit automatically turns on when any tripping occurs on the relay.

Navigation Keys

The relay is provided with four switches.

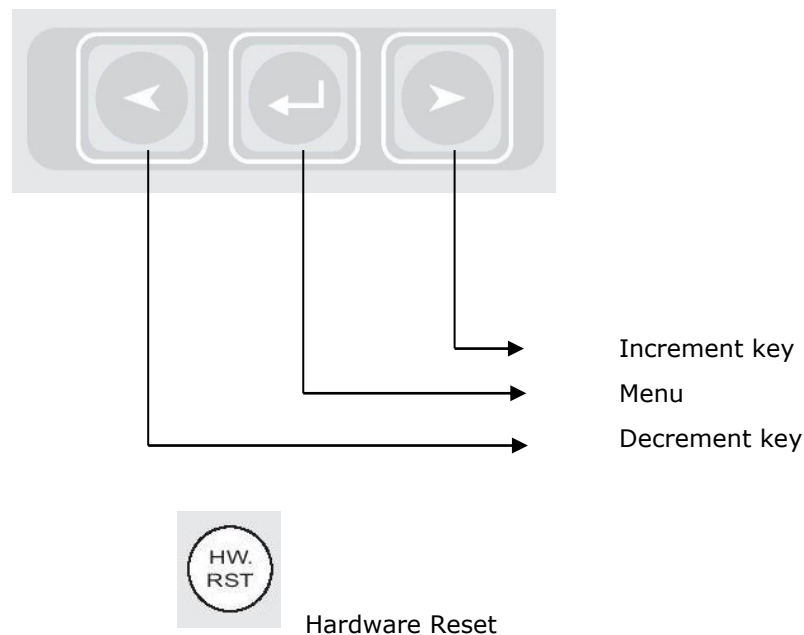

Menu key

- * Main key for entering relay setting mode.
- * If you want to select anything in the setting mode we can use this key.
- * To reset the relay from tripping mode.
- *

Increment key

- * If you want to raise any particular setting, we can use this option.
- * For saving any particular changes in the relay you can hire this key.
- * For viewing new options in the relay we can use this key.

Decrement key

- * If you want to lower any particular setting, we can use this option.
- * No need to save any unwanted mistakes in the relay you can use this key.
- * If you want to verify any previous settings in the relay you can opt this key.

INTERNAL ARCHITECTURE AND BLOCK DIAGRAM

INTERNAL SYSTEM LEVEL ARCHITECTURE- ANC 214

The internal system level architecture of ANC 214 relay including card to card architecture in brief is shown below.

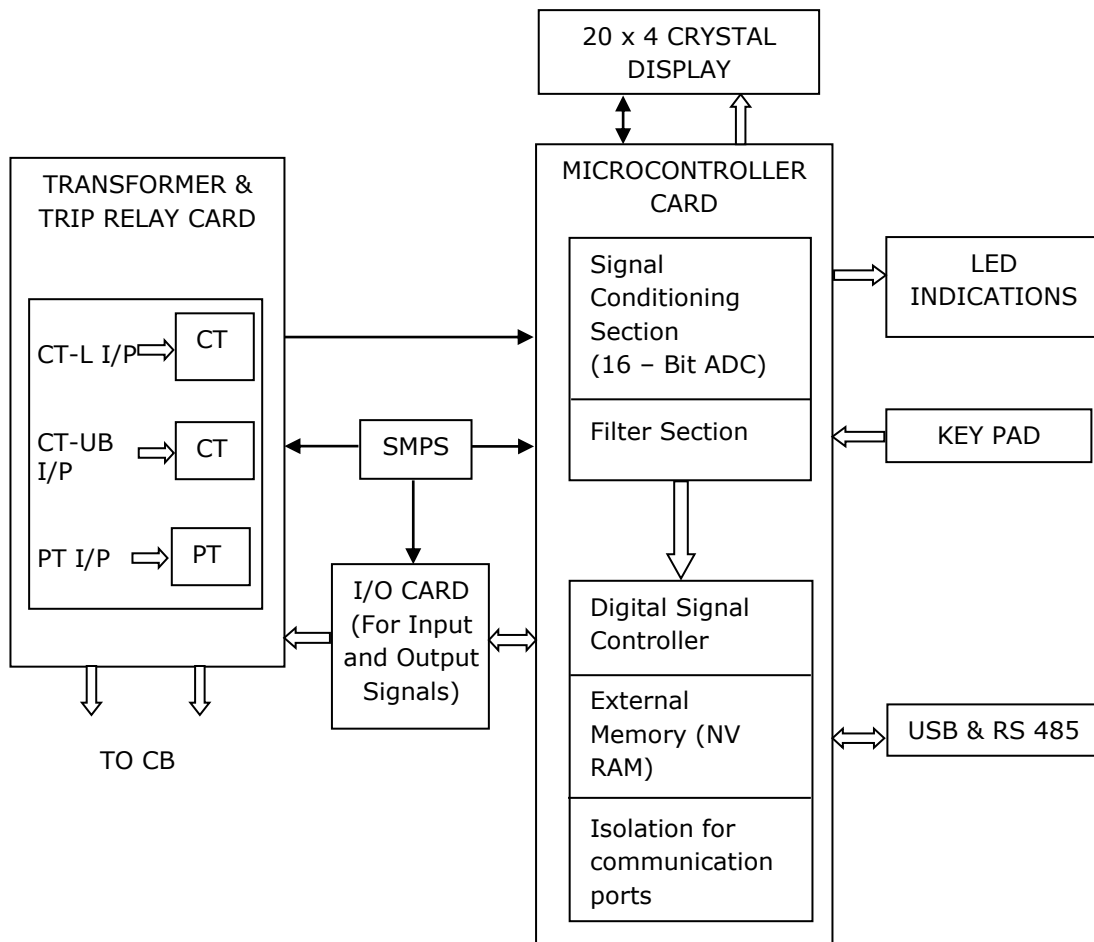

INTERNAL SYSTEM LEVEL ARCHITECTURE- ANC 402

The internal system level architecture of ANC 402 relay including card to card architecture in brief is shown below.

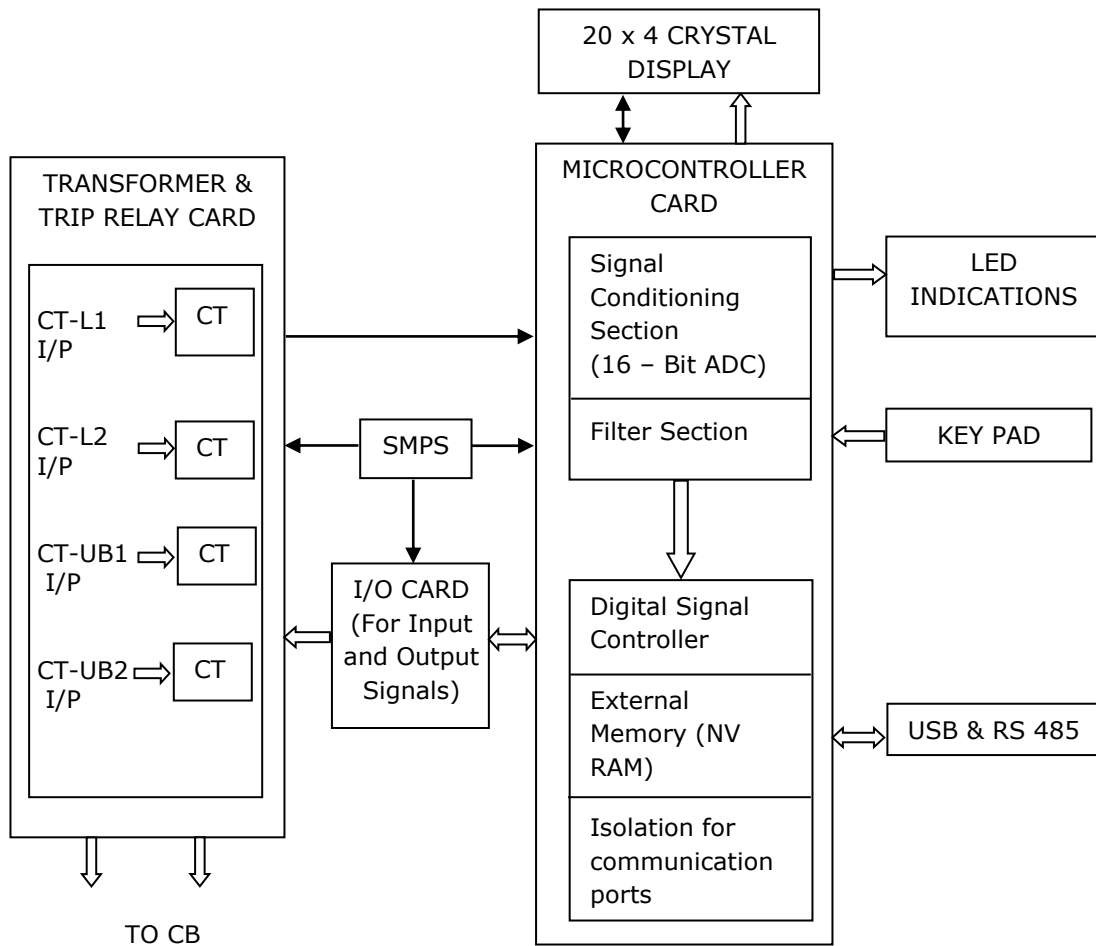

INTERNAL SYSTEM LEVEL ARCHITECTURE- ANC 033

The internal system level architecture of ANC 033 relay including card to card architecture in brief is shown below.

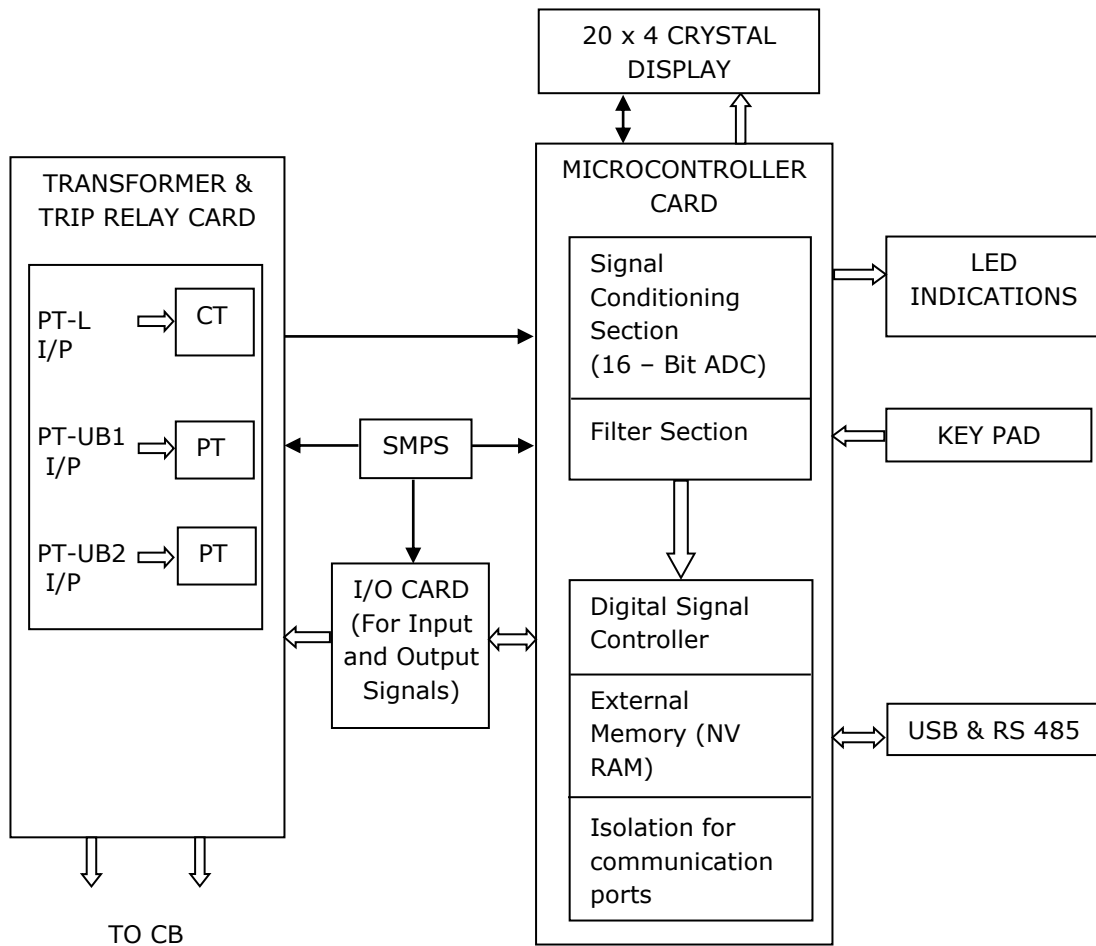

BLOCK DIAGRAM

ANC 214

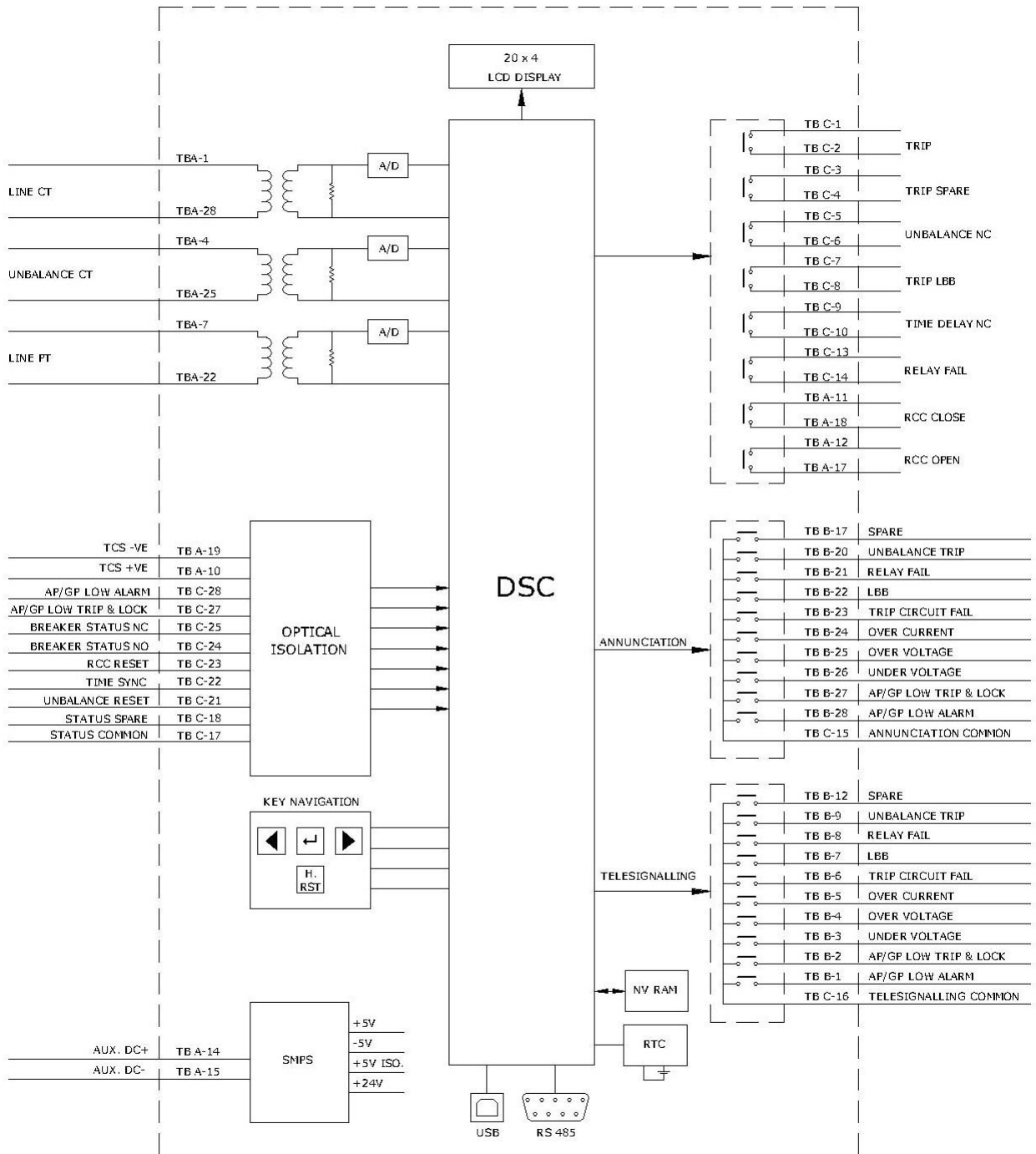

ANC 402

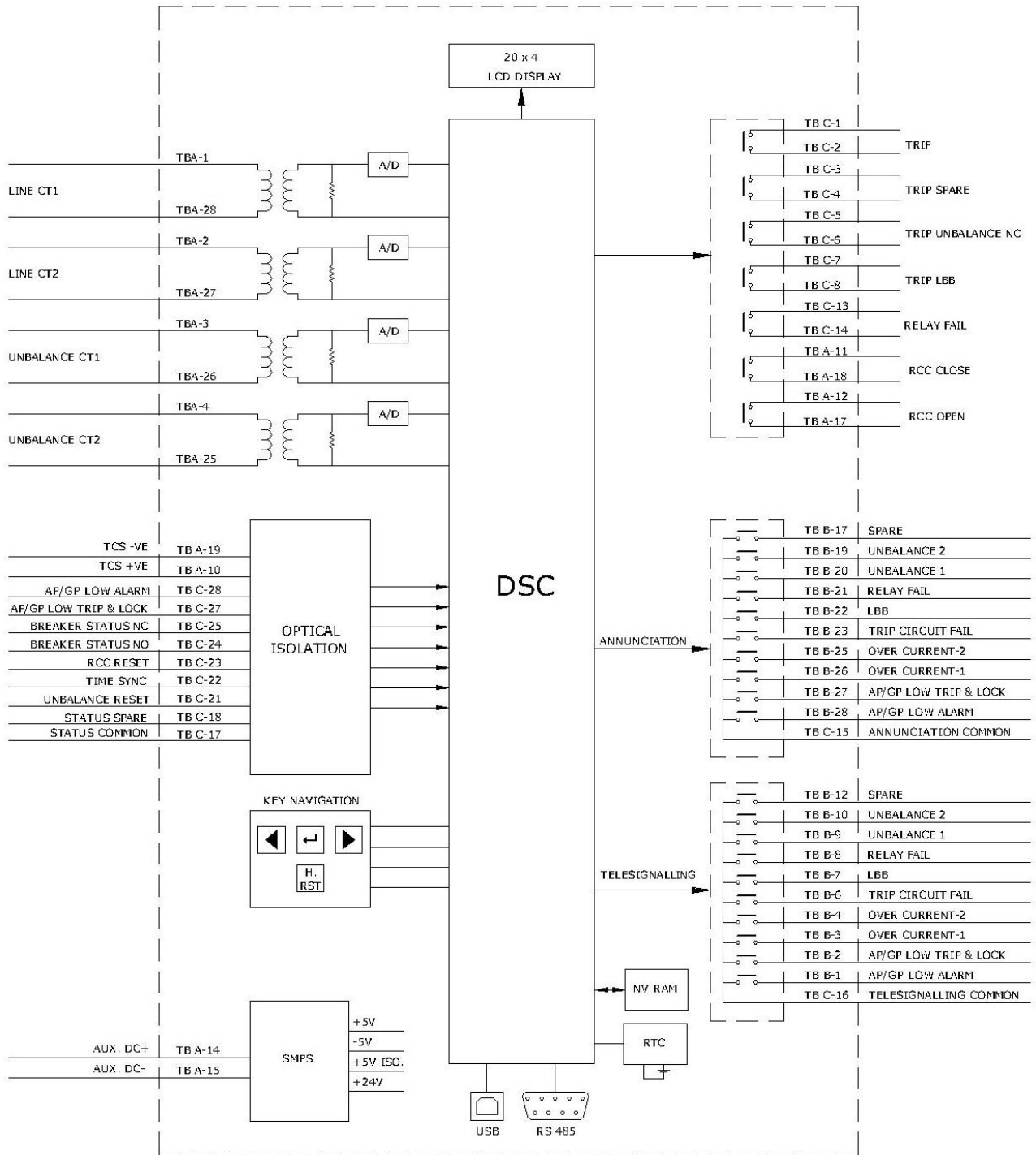

ANC 033

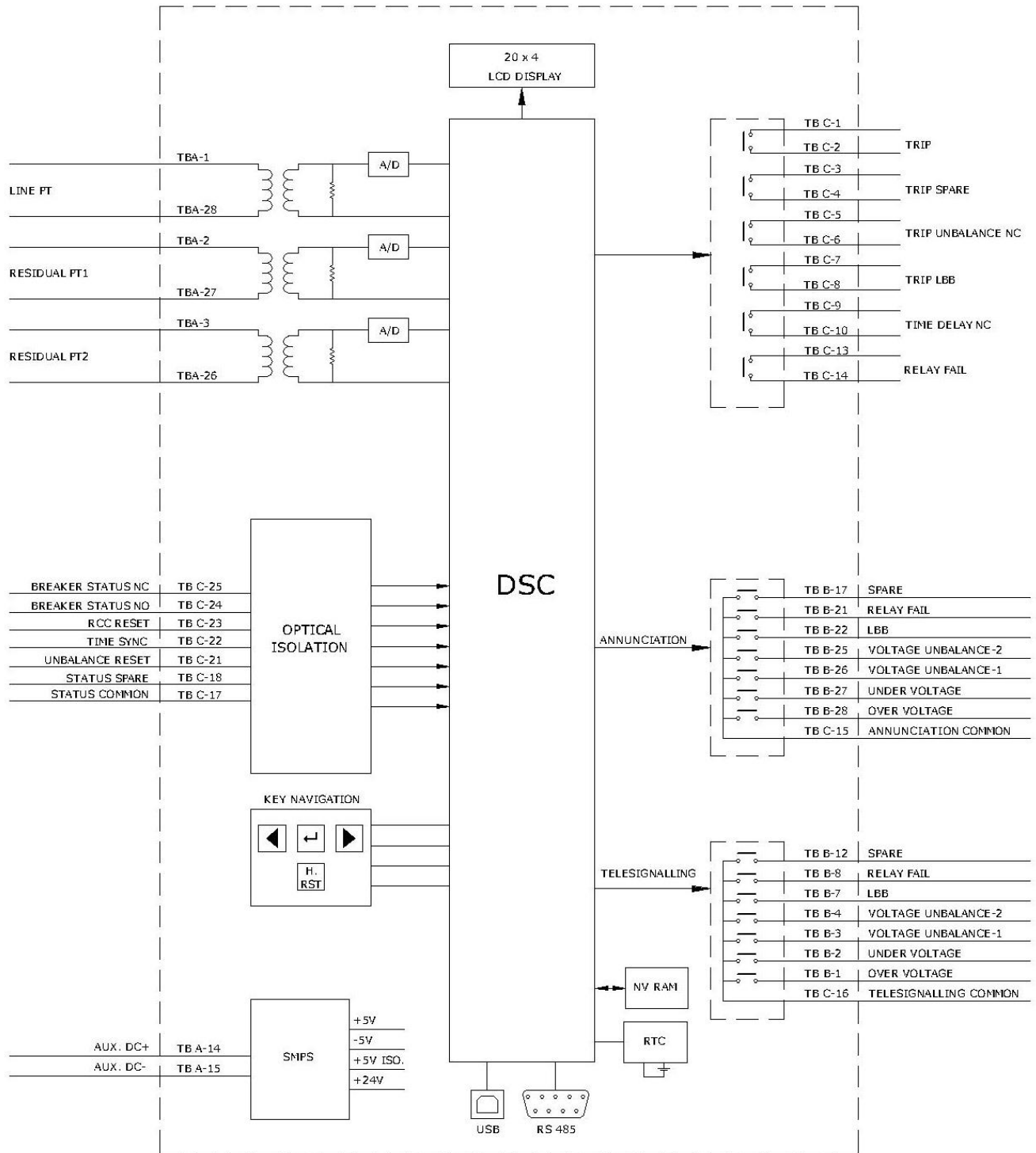

1. DSP Controller

The dsPIC DSC (Digital Signal Controller) is a 16-bit modified Harvard RISC (Reduced Instruction Set Computer) machine that combines the control advantages of a high-performance 16-bit microcontroller with the high computation speed of a fully implemented Digital Signal Processor (DSP).

The DSP controller continuously monitors the currents and voltages. Based on this the controller performs different calculations and whenever an abnormal condition occurs it distinguishes the type of fault and issues trip command to the circuit breaker.

2. Data Acquisition

The Current signals are scaled and isolated using Current Transformer (CT). The Voltage signals are scaled and isolated using Potential Transformer (PT). These isolated analog signals are filtered to minimize the effects of electromagnetic interference and noise in the high frequency range.

The analog signals are then fed to the Analog to Digital Converter which has a 16 bit resolution. The DSP controller will take the 32 samples per cycles of each Current for the computational purpose. If any fault occurs the parameters will be stored in to the non-volatile memory with date and time stampings and this can be downloaded for further analysis in the disturbance recorder.

3. Power Supply Module

This module gives the necessary regulated voltages like +5V, -5V, and +24V to various cards in the module. The normal operating voltage range is 45 VDC to 170 VDC. The +24V is used for driving the output relays in the I/O card and O/P relay card. The +5V and -5V is supplied to the processor, I/O card and Display PCB for normal relay operations. The isolated +5V is dedicated to the communication ports of the relay.

4. Communication Module

The relay is having 2 communications port, USB and RS 485. The relay is using IEC 60870-5-103 communication protocol for communication through RS485 and USB (Proprietary).

USB Communication Port

USB port is provided for uploading/downloading relay settings and events.

1. The software is capable of analyzing the peak, RMS & average values of current, Harmonic analysis of current waveforms and determination of fault clearing time.
2. Waveform pointed by user displays the current & sample value of the particular point.

RS 485 Communication Port

RS 485 port is provided for SCADA connectivity. Using RS485 port online fault data of critical parameters, disturbance record (Waveform), event record (Trip data), Automatic Supervision and Control (healthiness of Relay), Alarm and Event Handling, Data Acquisition, Calculating and Reporting, Parameter Setting, Resetting Indicating LEDs, Trip Circuit supervision, Relay Fail Indication etc can be downloaded. The communication complies with IEC 60870-5-103 protocol.



5. Man Machine Interface

Man Machine Interface is through a 20x4 LCD display and keys in the front panel of the relay. Necessary LEDs are provided in front panel for indicating the operation of different element.

6. Disturbance Recorder

The relay has the facility to record 50 cycles (45 pre-fault and 5 post faults) of fault waveforms. Latest 200 waveforms of Current can be stored in the relay. This data is retrievable through USB & RS 485 communication ports using UI software and SCADA respectively.

7. Event Recorder & Disturbance Recorder

The relay is capable of storing 5000 number of events with date and time stamping of 1ms accuracy. The event data comprise of:

Tripping of different protection elements (I, Fault clearing time, Fault date & time)

Trip circuit supervision

Relay pick up

Relay reset

CB Trip

CB Close

Change of status input

Relay setting changed (GUI & Keypad)

Relay Fail.

ENERGIZING THE RELAY

1. Before turning ON the relay, proper earthing should be provided.
2. Visual Inspection for any physical damage in housing, display etc shall be checked.
3. Operating voltage range: **45 to 170 VDC**
Operating Voltage: **110 VDC**
4. Prefer regulated power supply of 110VDC.
5. Auxiliary power supply shall be provided to the terminals 14 & 15 of TB-A with the help of an MCB.
6. Switch on the power supply. Measure the voltage between the terminals 14 & 15 of TB-A, and ensure that the voltage is within the normal operating range.
7. After the relay is powered ON, the following shall be noticed.
8. Protection healthy LED glow green in color which indicates that the relay is functioning OK, otherwise it goes amber.



PCB DESCRIPTION

The relay comprises of the following hardware.

Main PCBs. –Display PCB, Communication PCB, Controller PCB, Stack PCB, Trip relay & transformer PCB, SMPS PCB, I/O & status PCB, Back panel PCB.

Display PCB: The Display PCB is mounted at the front plate of the unit. It consists of the 20x4 LCD, LED indications, Keyboard circuits, and LED controller.

Controller PCB: The Controller PCB is mounted on the back side of the Display PCB. This PCB consists of major components such as DSP controllers, ADC and its filter circuits, Memory ICs, RTC. The Analog signals are filtered and digitized in this board. The DSP takes decision based on this digital samples and initiates necessary commands.

Communication PCB: The communication PCB is mounted at the front side. This PCB supports the communication through USB for data exchange. Also the Hardware Reset Switch is mounted in this PCB.

Stack PCB: Internal communications between the PCB's are ensured with the help of stack PCB.

Trip relay &Transformer PCB: All the CTs, PTs and Tripping Relays are assembled in this board. This board will give necessary trip commands to the master trip relay or breaker which is installed in the yard. Necessary relay initiating signals are wired to these output relays from the Controller Board.

SMPS PCB: The SMPS PCB provides the necessary Power supply voltages to the different PCBs mounted inside the relay. The SMPS is a DC-DC converter. The SMPS provides +24V, +5V, -5V and isolated +5 V. The +24 V supply is used for the driving the output relays in the I/O PCB and Trip Relay PCB. The +5V and -5V is supplied to the controller PCB, Display PCB, and I/O PCB for normal operations. The isolated +5V is dedicated to the communications ports of the relay.

I/O & status PCB: The I/O PCB deals with the necessary I/O lines such as Input status lines and Digital Output contacts. A separate controller provided in this board performs the necessary I/O operations in conjunction with the DSP controller in the Processor PCB. The I/O PCB is mounted vertically on to the stack PCB.

Back PCB: This PCB consists of terminal blocks for external interface with the site and power connector which connects SMPS, I/O and CT PT PCB's. The RS 485 port is also mounted in this PCB. The terminal block (TB-A) is having CT shorting facility. Since the rack with Terminal Blocks is having the CT shorting facility, the relay can be withdrawn.



RELAY SETTINGS AND ALGORITHM

ANC 214

After Power ON, the relay boot screen shows



Then comes the online parameter display

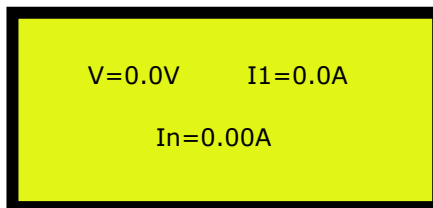

To scroll between online displays, press **Right** key after holding **↵** key.

Setting Mode

Press and hold **↵** for 5 seconds

Relay will enter to setting mode.

Enter the password and press **↵** key. The default password setting is '1000'

To change settings:

- a) Press **↵** to change the settings.
- b) Press **Right** key to increment
- c) Press **Left** key to decrement
- d) Press **↵** to accept change.
- e) To coming back to main **MENU** while operating, press **Left** and **Right** key simultaneously.
- f) Repeat the process for all settings
- g) After completing the settings, the relay shows the message '**SETTINGS UPDATED**' and returns to the operating mode.

ANC 402

After Power ON, the relay boot screen shows



Then comes the online parameter display

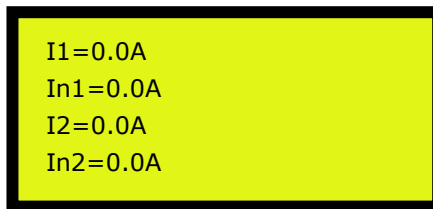

To scroll between online displays, press **Right** key after holding  key.



Setting Mode

Press and hold  for 5 seconds

Relay will enter to setting mode.

Enter the password and press  key. The default password setting is '1000'

To change settings:

- a) Press  to change the settings.
- b) Press **Right** key to increment
- c) Press **Left** key to decrement
- d) Press  to accept change.
- e) To coming back to main **MENU** while operating, press **Left** and **Right** key simultaneously.
- f) Repeat the process for all settings
- g) After completing the settings, the relay shows the message '**SETTINGS UPDATED**' and returns to the operating mode.

ANC 033

After Power ON, the relay boot screen shows



Then comes the online parameter display

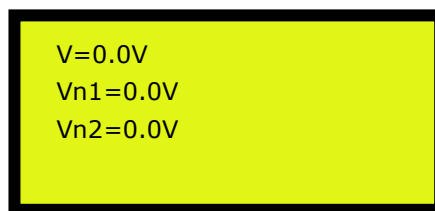

To scroll between online displays, press **Right** key after holding \leftarrow key.

Setting Mode

Press and hold \leftarrow for 5 seconds

Relay will enter to setting mode.

Enter the password and press \leftarrow key. The default password setting is '1000'

To change settings:

- a) Press \leftarrow to change the settings.
- b) Press **Right** key to increment
- c) Press **Left** key to decrement
- d) Press \leftarrow to accept change.
- e) To coming back to main **MENU** while operating, press **Left** and **Right** key simultaneously.
- f) Repeat the process for all settings
- g) After completing the settings, the relay shows the message '**SETTINGS UPDATED**' and returns to the operating mode.

Relay Settings Algorithm

ANC 214

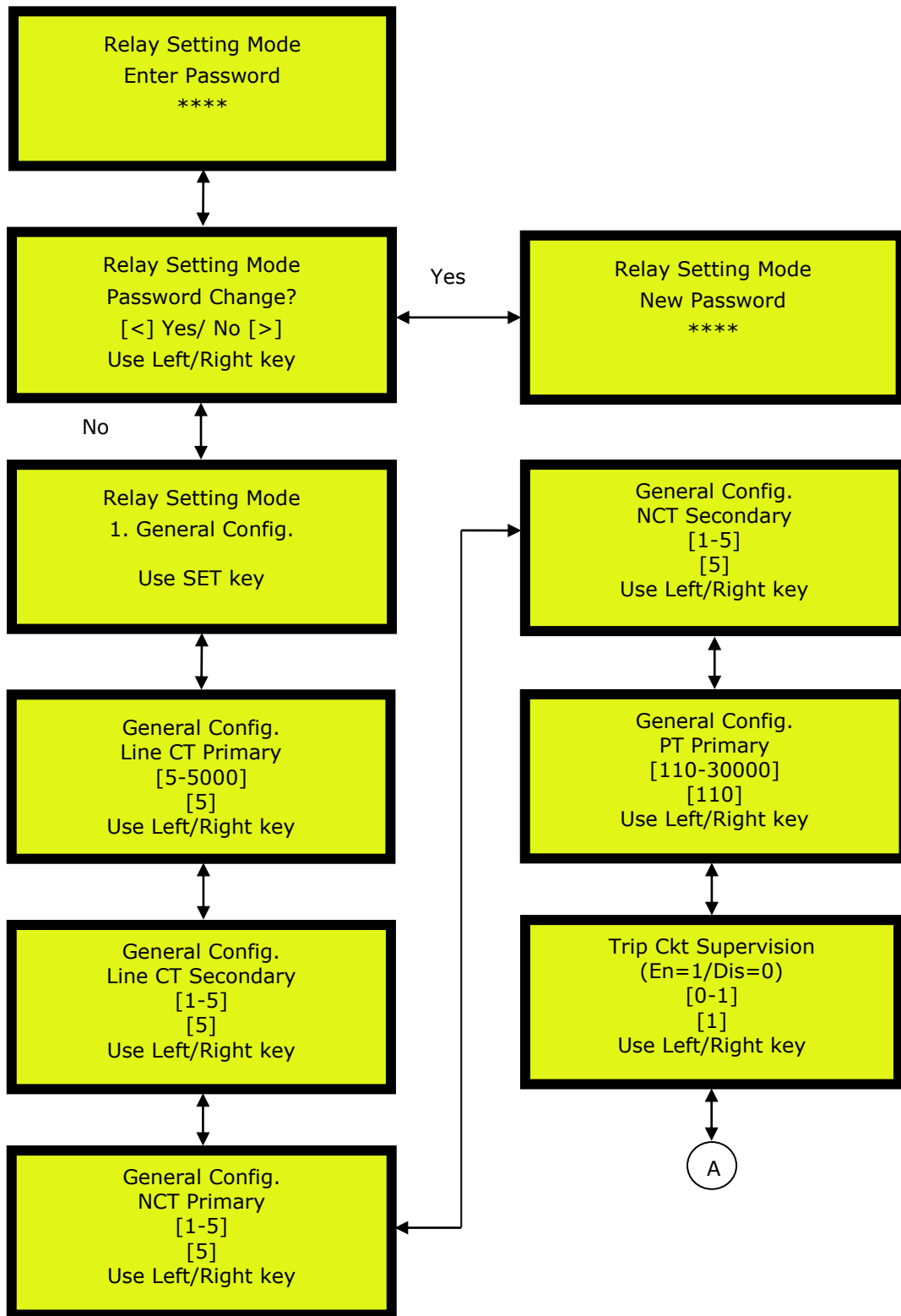

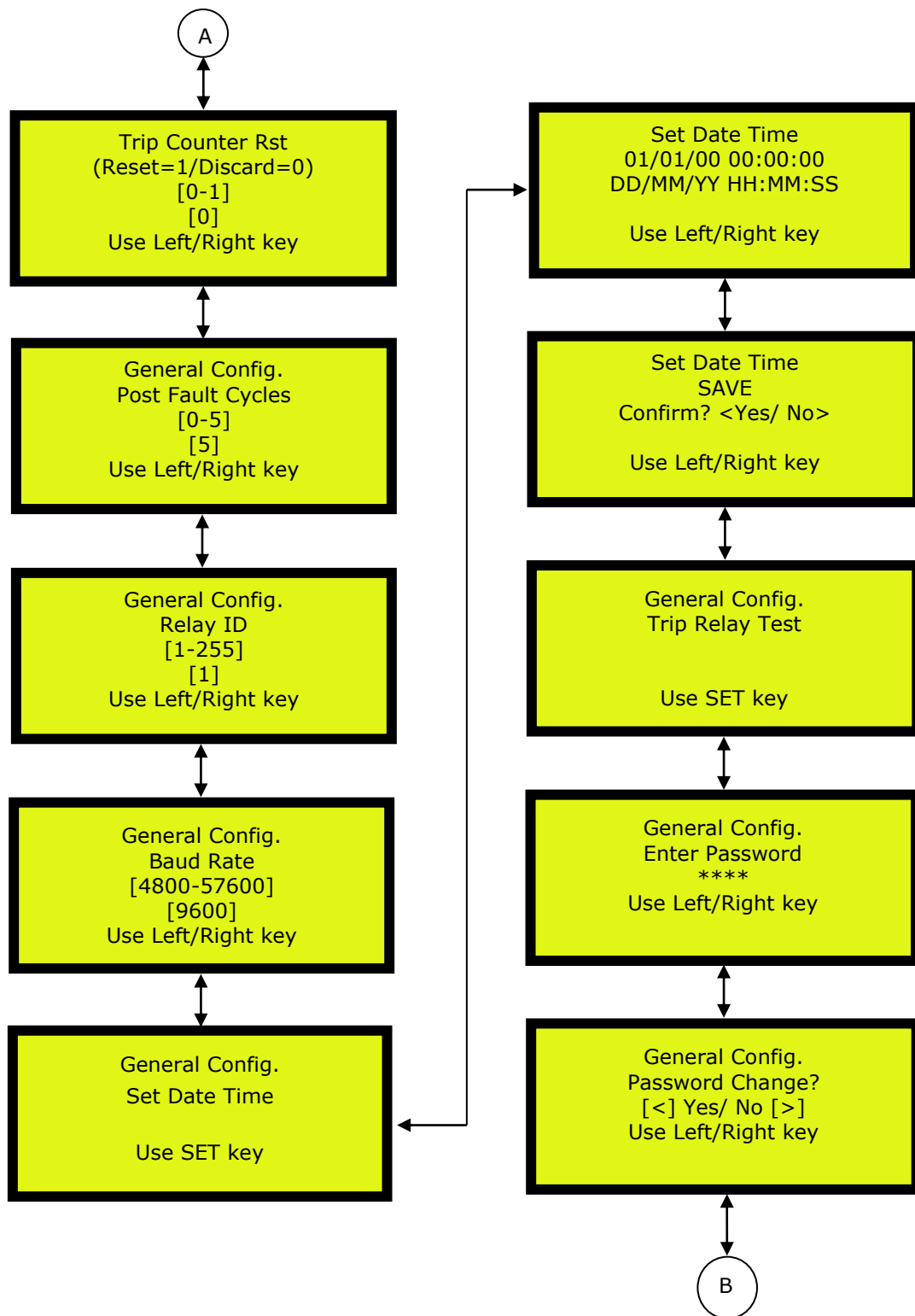

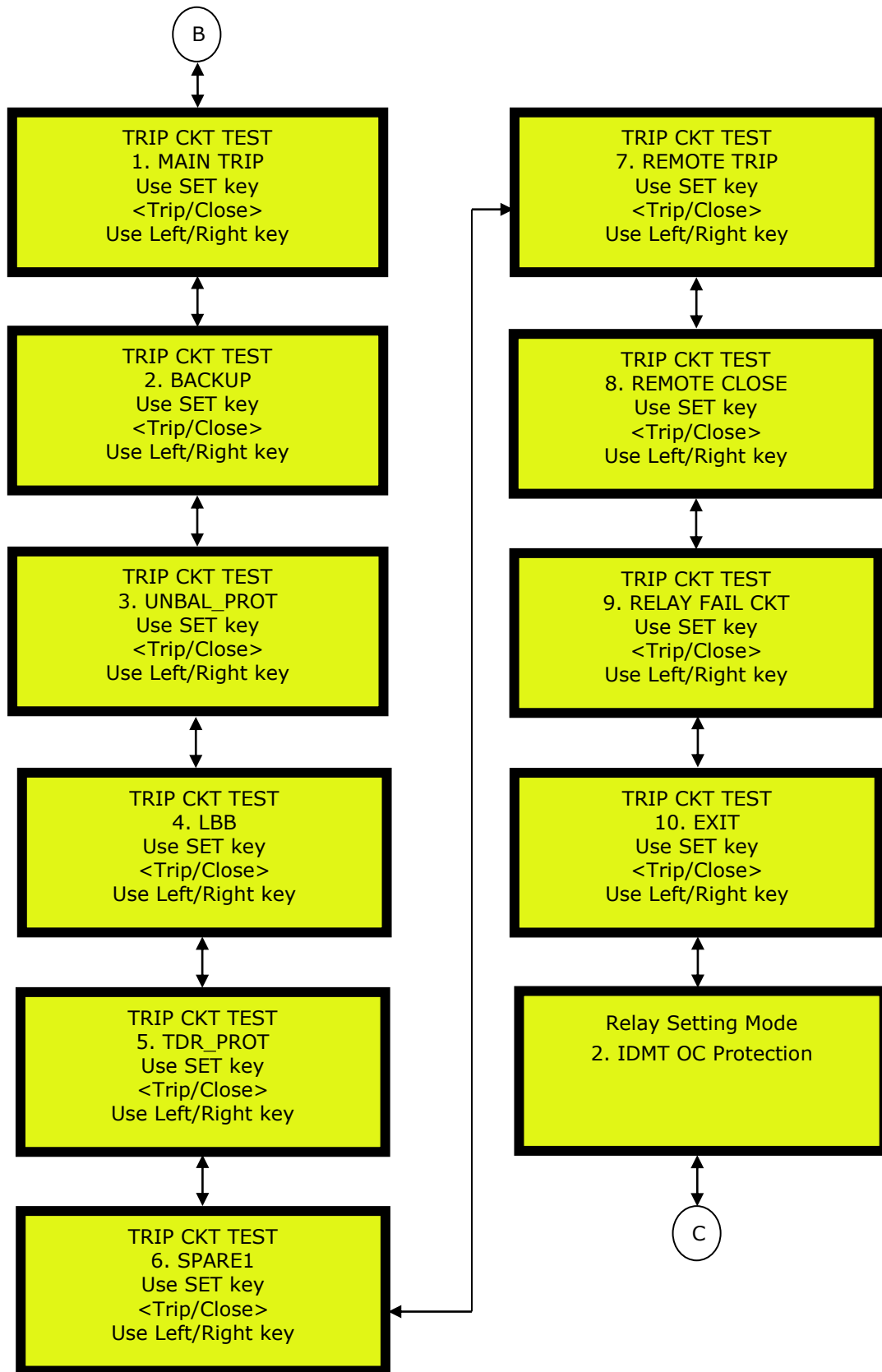

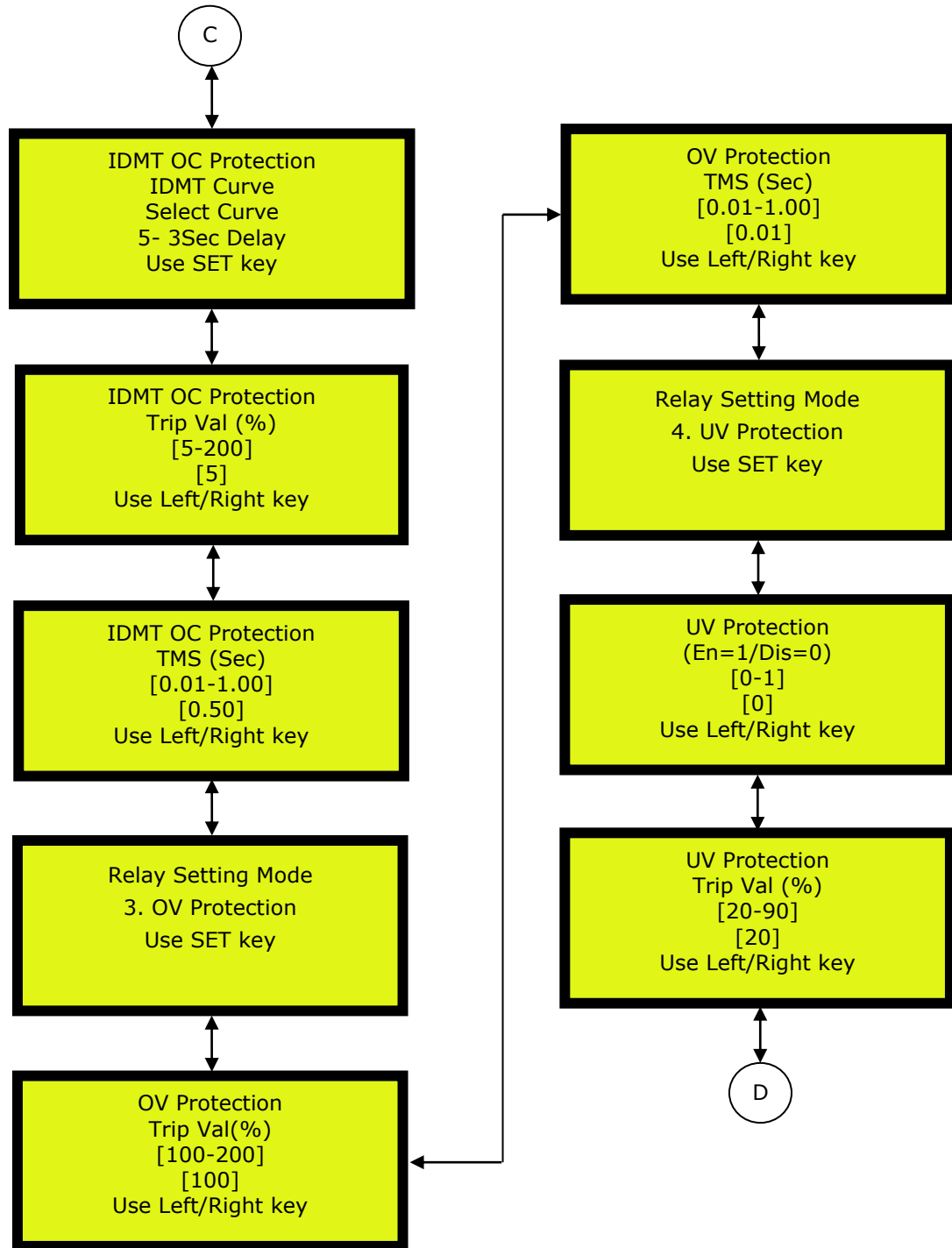

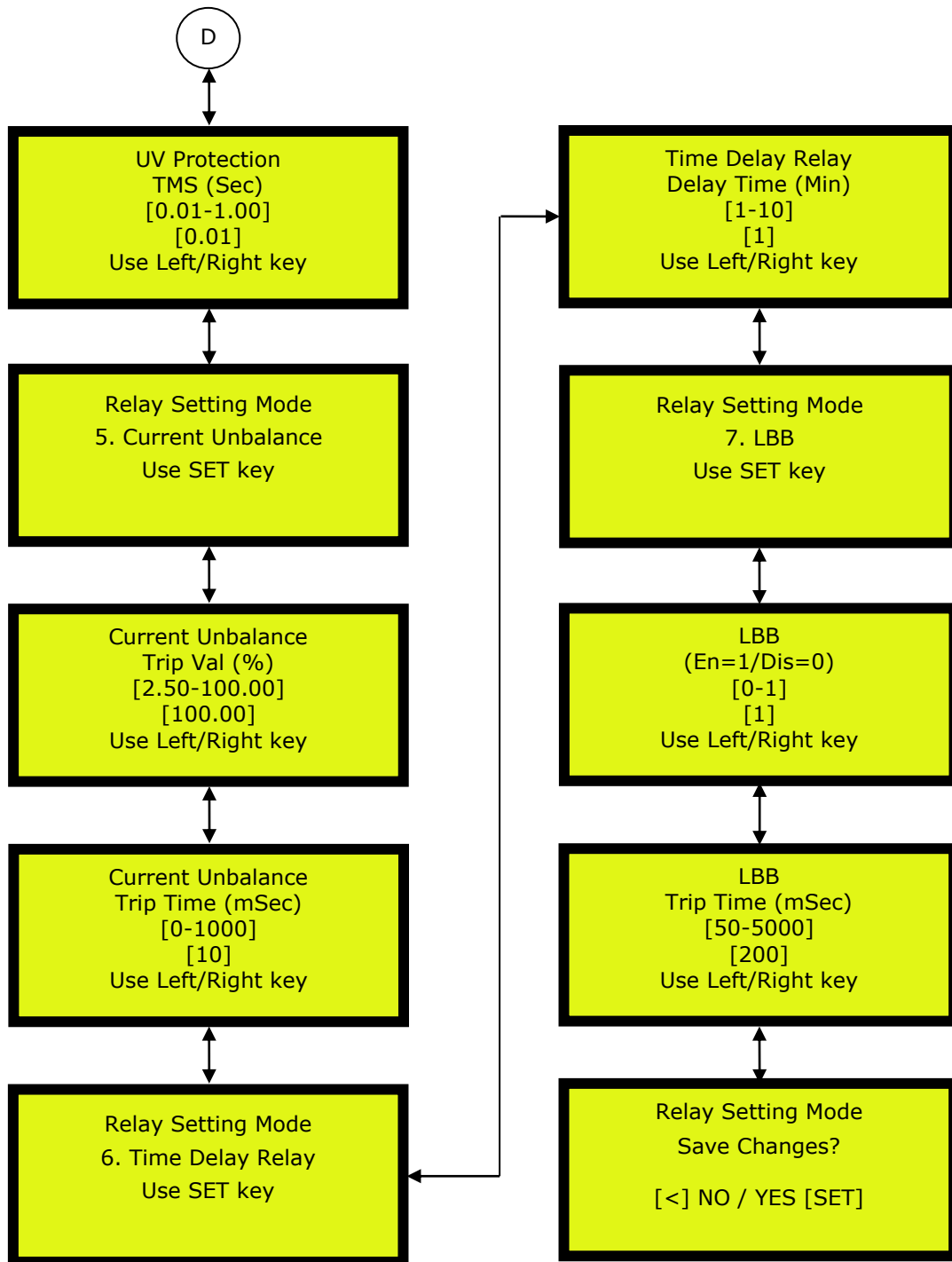

ANC 402

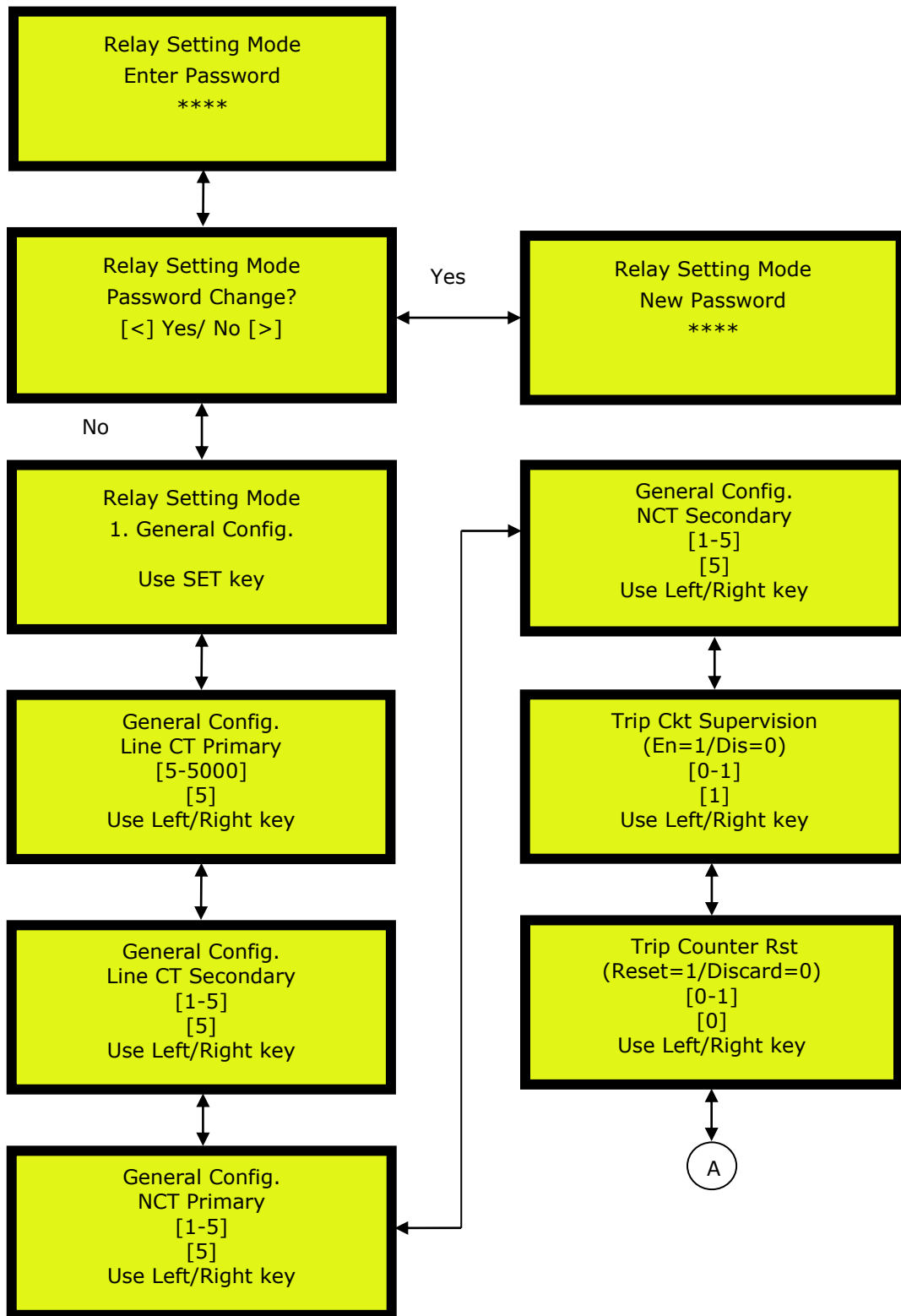

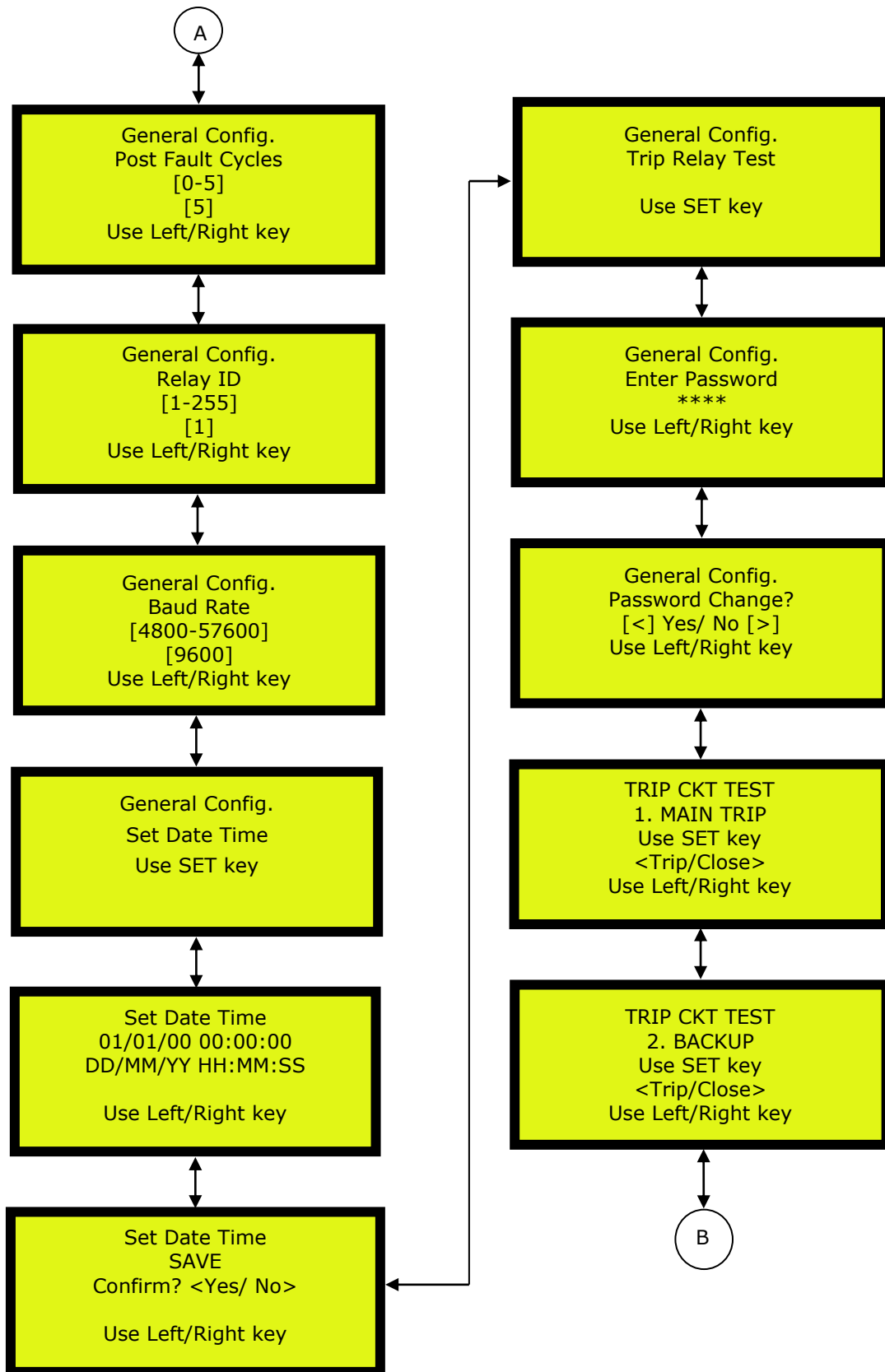

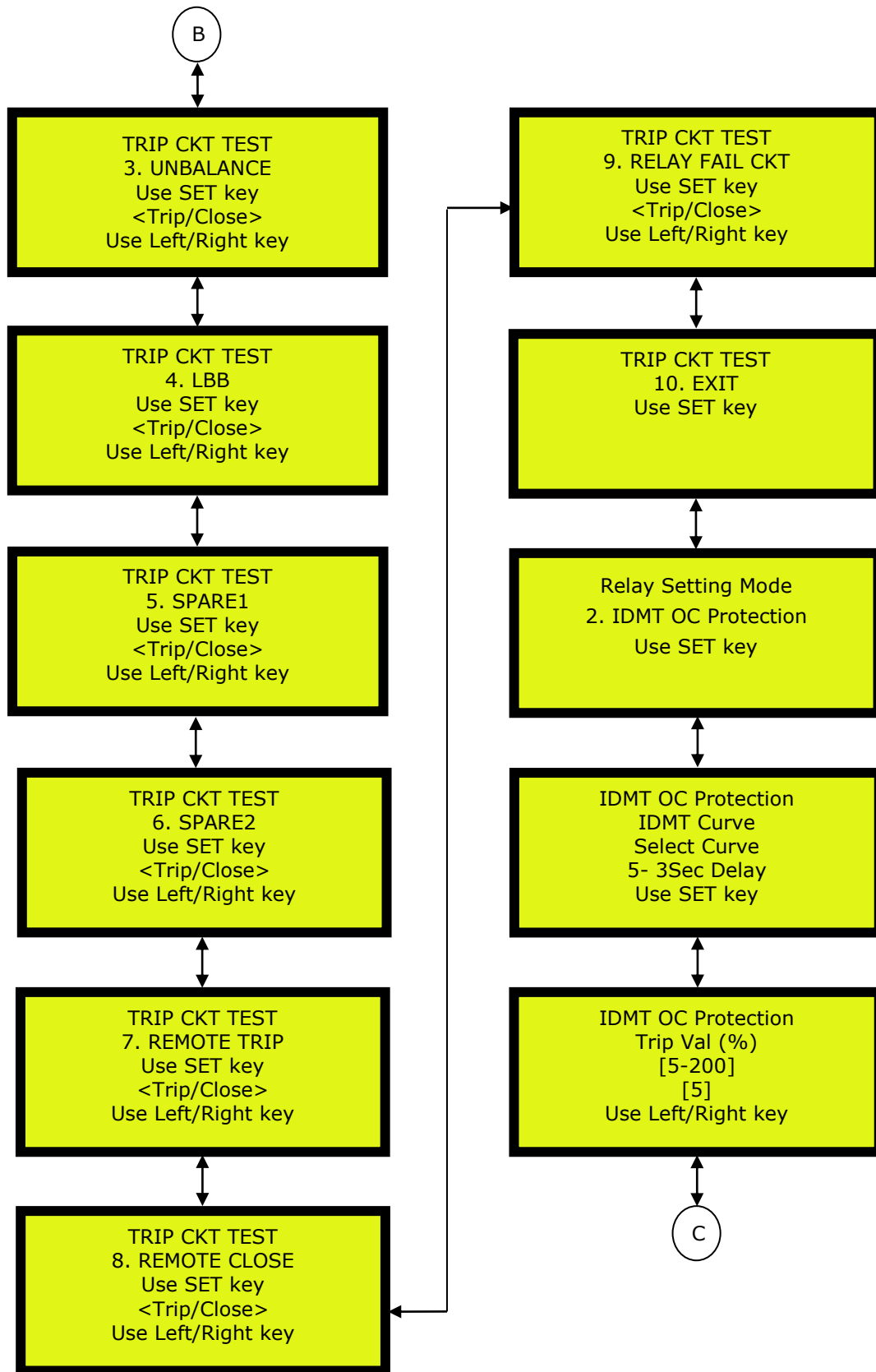

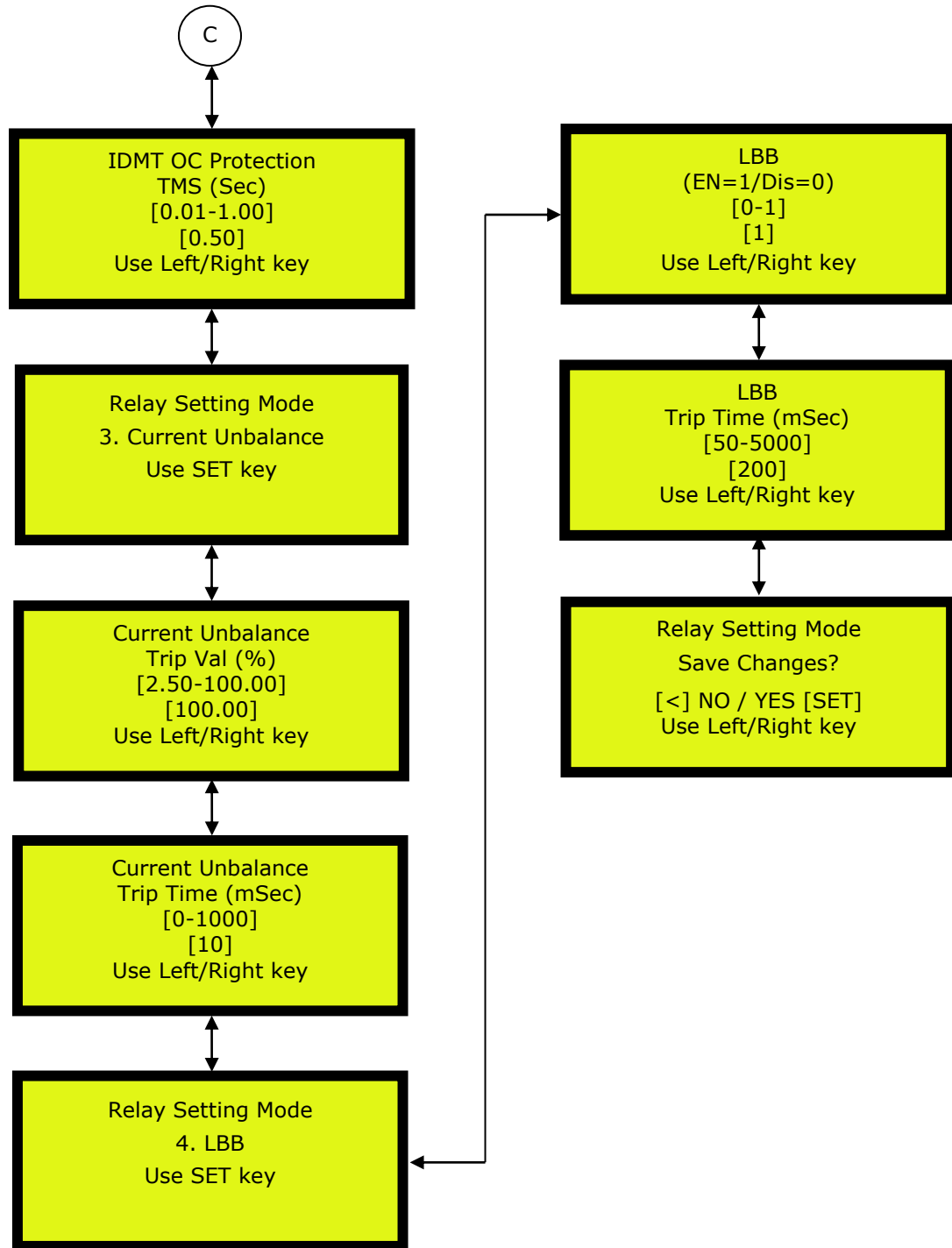

ANC 033

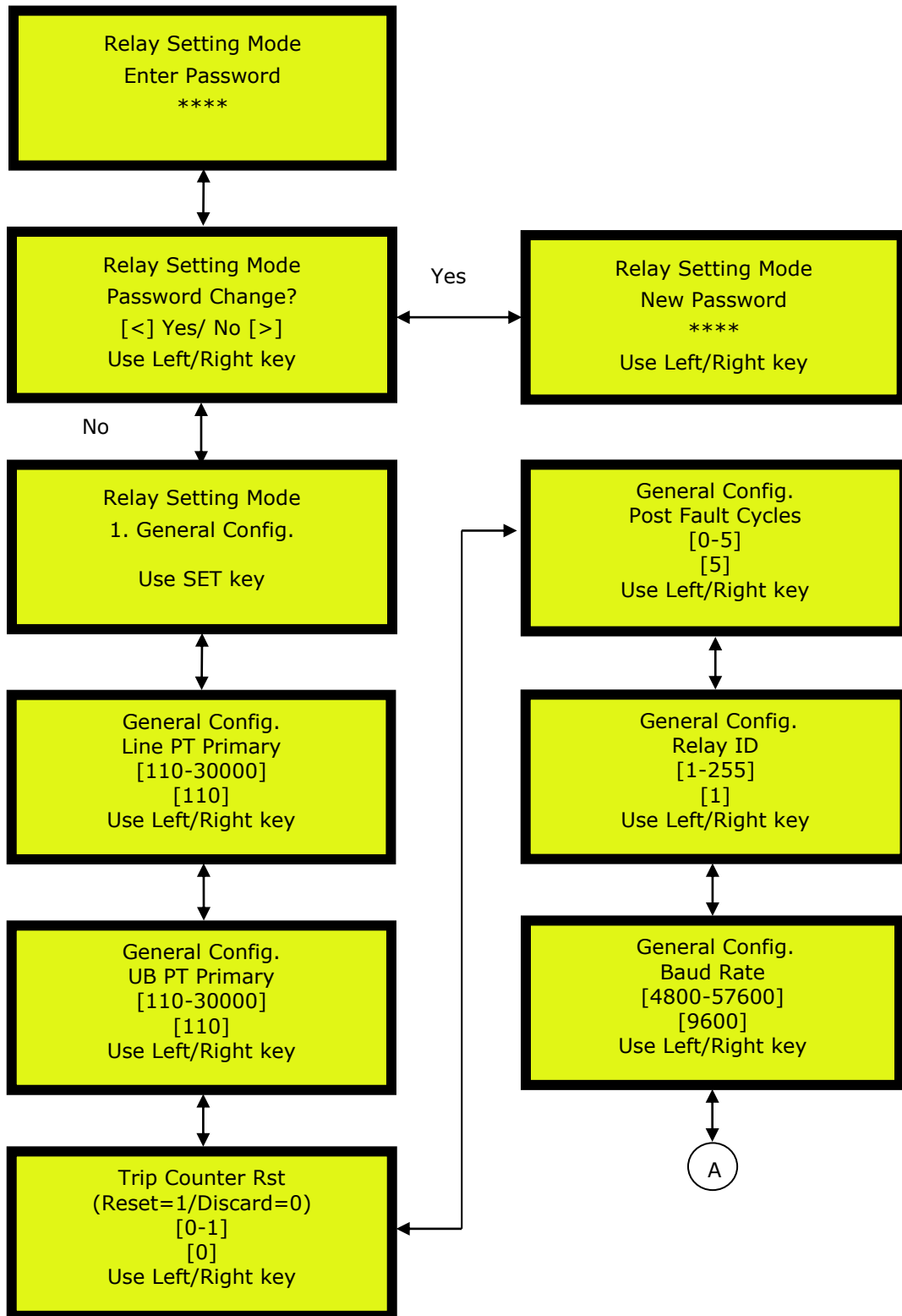

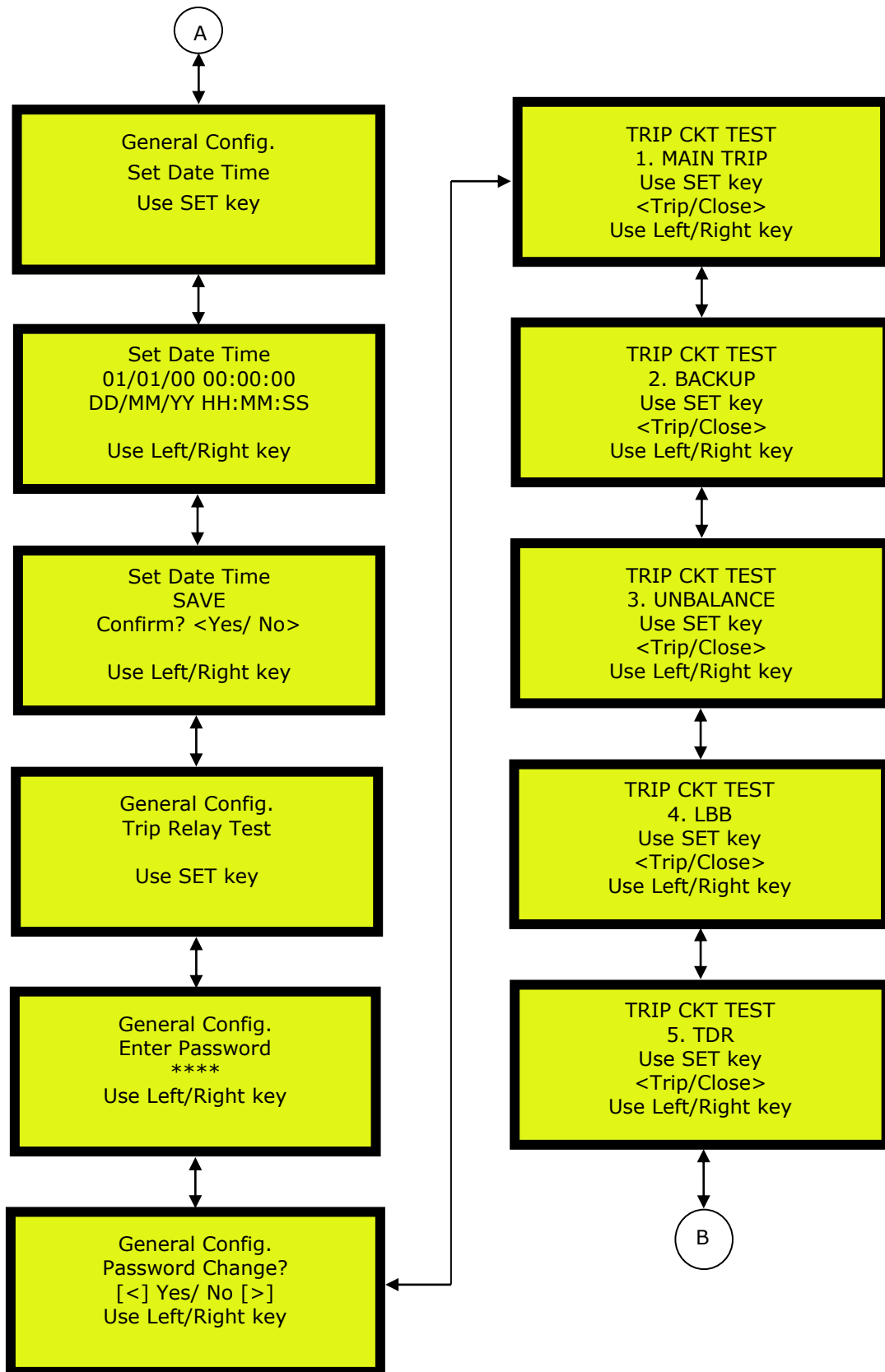

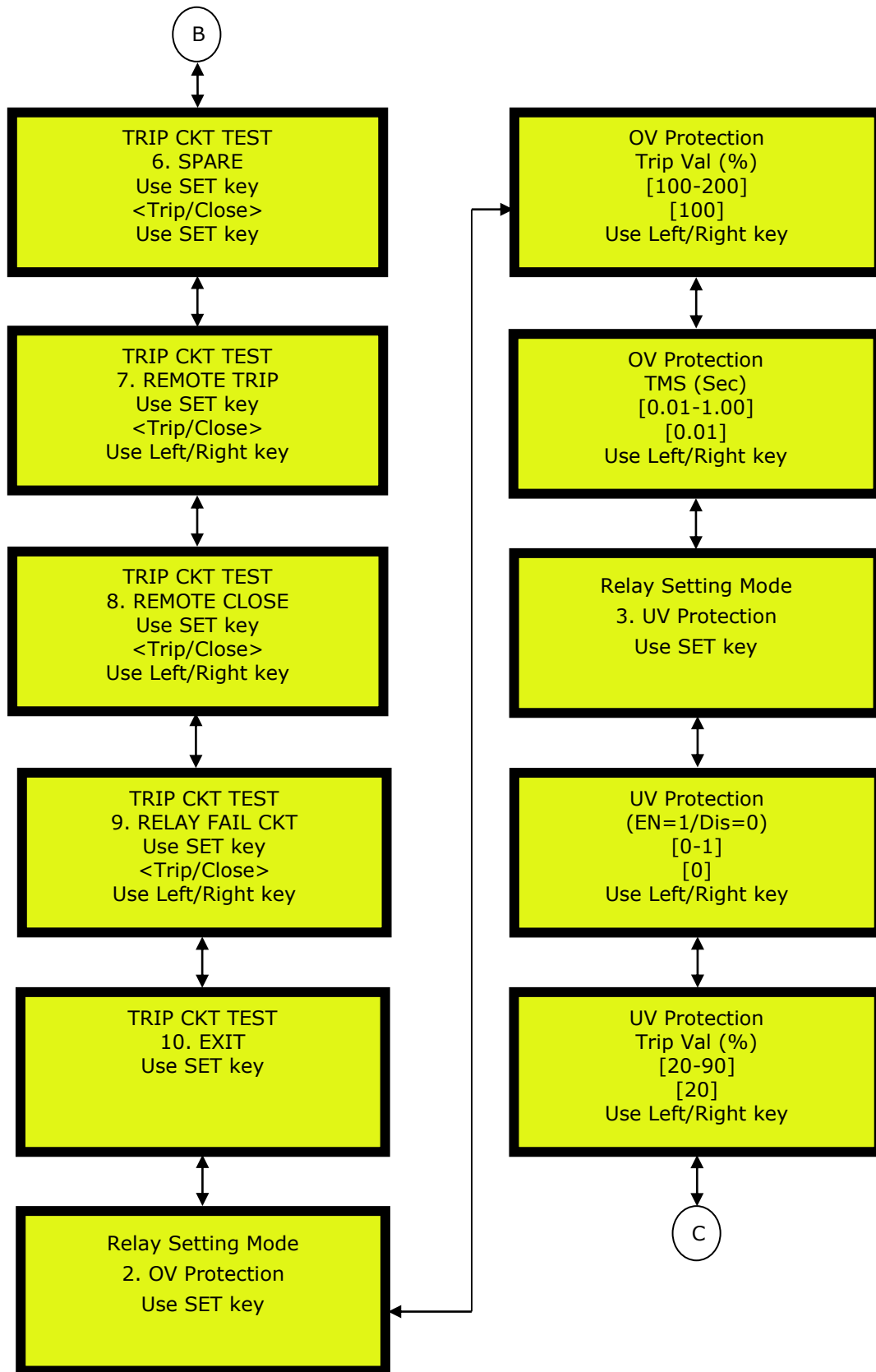

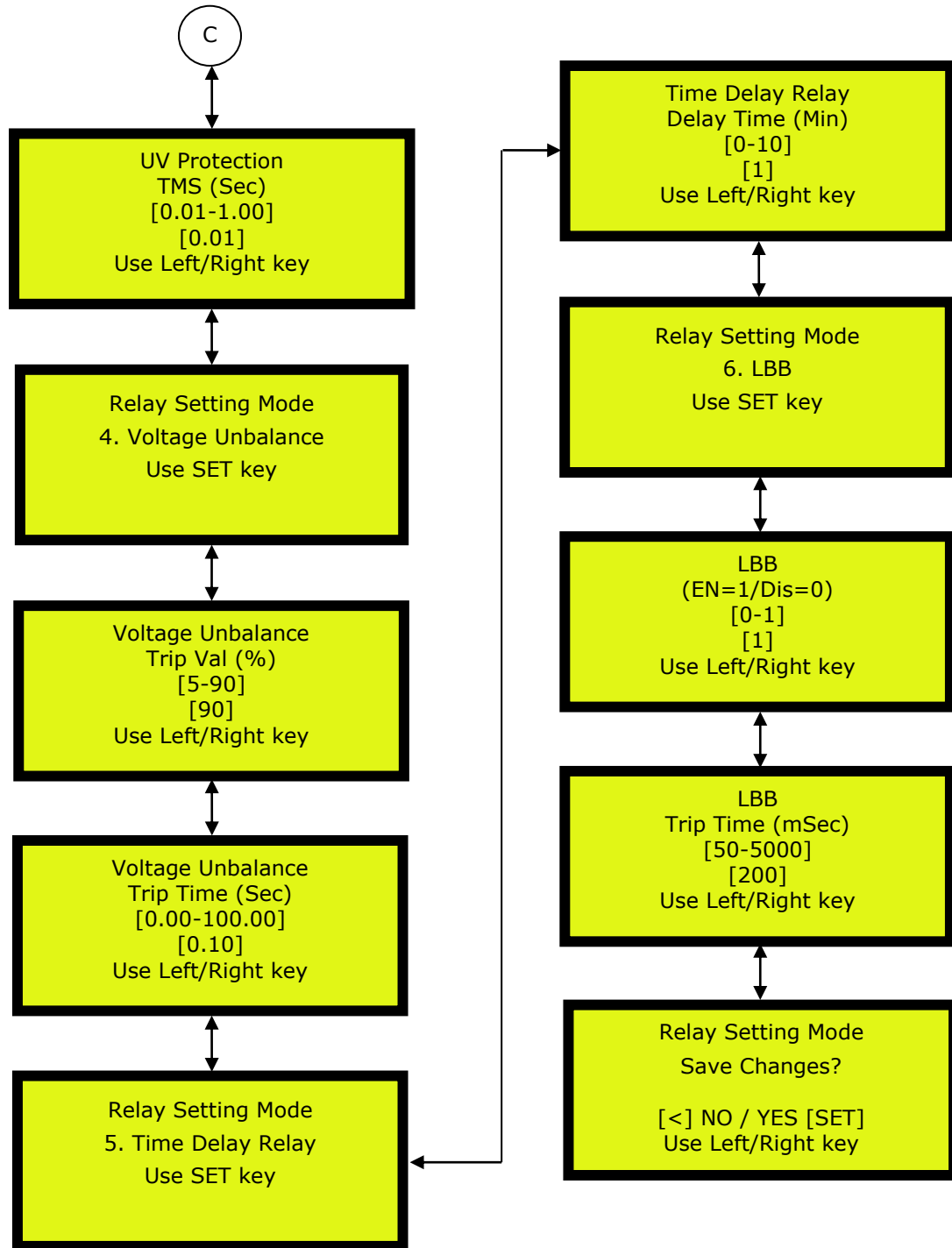

TECHNICAL DATA & CHARACTERISTIC CURVES



CONTENTS

DESCRIPTION OF PROTECTION FUNCTIONS

TECHNICAL SPECIFICATIONS

GENERAL SETTINGS

TB DETAILS

RELAY CONFORMING STANDARDS



DESCRIPTION OF PROTECTION FUNCTIONS

1. Over voltage protection

The relay provides protection against over voltage with an over voltage element of inverse time characteristics (IDMT operating curve $1.5N=7$ sec at TMS 1.0). The over voltage relay is energized from the potential transformer connected to the main bus bar on the incoming side of the circuit breaker. The over voltage setting ranges from 100 to 200 % in steps of 1% and the time multiplier setting from 0.01 to 1.0 in steps of 0.01.

$$\text{Trip Time} = 1.23 * (\text{TMS} / \log V)$$

$$V = \text{Injected Voltage} / \text{Set Voltage}$$

2. Under voltage protection

An under voltage element with inverse time characteristics (IDMT curve is 5.0sec at 0 voltage at TMS=1.0) is provides protection against under voltage. The voltage setting ranges from 20 to 90% in steps of 1% and TMS from 0.01 to 1.0sec in steps of 0.01.

$$\text{Trip Time} = \text{TMS} (1.68 + 1 / \log (2 - V))$$

$$V = \text{Injected Voltage} / \text{Set Voltage}$$

3. IDMT over Current Protection

The IDMT element use standard inverse of characteristics (3 sec Delay Curve). Its graphical representation as shown in Figure.

3 sec Delay Curve

$$t = 3k / \log [\text{PSM}]$$

Where,

k= Time Multiplier Setting (TMS)

t = Operating time in second

TMS = Time multiplier setting

PSM=Fault Current/Plug Setting

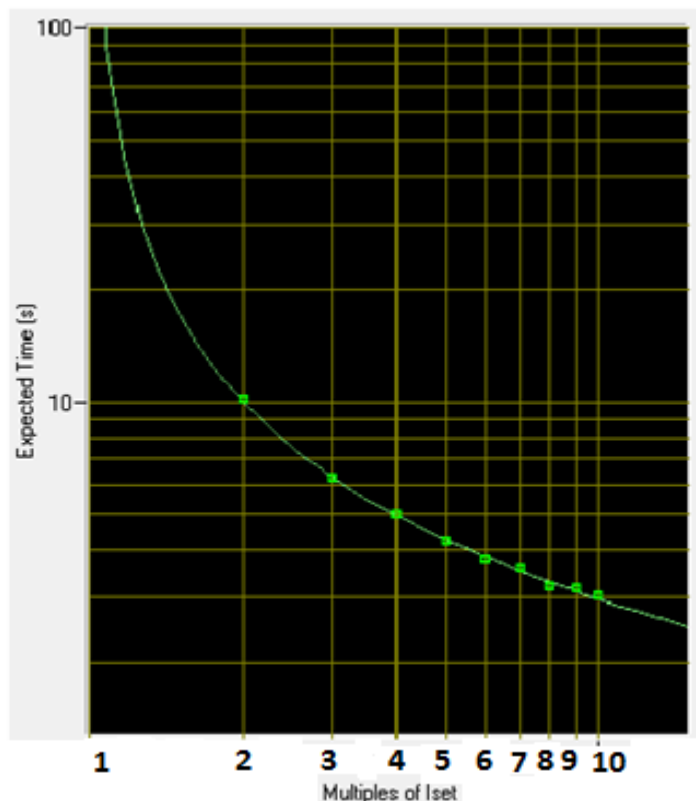

4. Current unbalance Protection

The capacitor bank is protected by means of an unbalance current protection. The capacitor bank is connected as a bridge and an unbalance sensing current transformer is provided. The current is settable from 2.5 to 100% in steps of 0.50 % and operating time from 0 to 1 sec in steps of 1ms.

TECHNICAL SPECIFICATIONS

Sl. No	Specification	REF.	Particulars
1.	Auxiliary Supply	V _{DC}	45 to 170 VDC
2.	Voltage Input (rated)	V _n	110V
3.	Current Input (rated)	I	5A AC
4.	Frequency	F _n	50 Hz
5.	VA Burden on CT		Less than 0.5 VA
6.	VA Burden on PT		Less than 0.5 VA
7.	VA burden on Aux		Less than 15 Watts(energized) Less than 10 watts(de-energized)
8.	Operating Temp Range		-10°C to + 60 °C
9.	Max. & Minimum relative humidity		100% & 22%
10.	Continuous Current Carry Capacity of CT		3I _n ; 15A
11.	Continuous Voltage Carry Capacity of PT		1.15 of rated value
12.	Thermal Withstand for CT		40I _n for 1 sec
13.	Thermal Withstand for PT		2 times rated value for 10 sec
14.	Contact details		
	a)Current carrying capacity		5A
	b) Making and carry for 3 sec at 250V,50Hz		30A
	c) Making capacity at 250V,50-60Hz AC		5A
	d)Breaking Capacity		
	AC 220V, 50-60Hz, Cos ϕ =0.4		5A
	DC 220V, L/R= 45ms		0.5A
15.	Type of communication ports		USB and RS485
16.	Overall dimensions		
	Width		263 mm
	Height		173 mm
	Depth		330 mm
17.	Weight		6.9 kg approx.

RELAY SETTINGS

ANC 214

General Settings	Particulars
Password protection (YES/NO)	0000-9999
1. General Config.	
Line CT Primary	5 to 5000A in steps of 5A
Line CT Secondary	1A to 5A in steps of 1A
NCT Primary	1A to 5A in steps of 1A
NCT Secondary	1A to 5A in steps of 1A
PT Primary	110 to 30000V in steps of 10V
Trip Circuit Supervision	En/Dis
Trip counter Reset	Reset/Discard
Post fault cycle	0 to 5 in steps of 1
Relay ID	1 to 255 in steps of 1
Baud Rate	4800-57600 in steps of 200
Set Date Time	(Yes/No) DD/MM/YY HH:MM:SS
Trip Relay Test	
2. IDMT OC Protection	
IDMT Curve Selection	1- Normal Inv. 2- Extremely Inv. 3- Very Inv. 4- Restricted Inv. 5- 3 Sec Delay 6- 1.3 Sec Delay 7- Long Time Delay
Trip Val (%)	5-200% in steps of 1%
TMS(Sec)	0.01-1.00 Sec in steps of 0.01 Sec
3. OV Protection	
Trip Val (%)	100 to 200% in steps of 1%
TMS (Sec)	0.01 to 1.00Sec in steps of 0.01 Sec
4. Under Voltage Protection (EN/DIS)	
UV	EN/DIS
Trip Val (%)	20 to 90% in steps of 1%
TMS (Sec)	0.01 to 1.00 Sec in steps of 0.01 Sec
5. Current Unbalance	
Trip Val (%)	2.50 to 100% in steps of 0.5%
Trip Time(mSec)	0 to 1000mSec in steps of 1mSec
6. Time Delay Relay	
Delay Time(Min)	0 to 10Min in steps of 1 Min.
7. LBB	
LBB	EN/DIS
Trip Time	50 to 5000ms in steps of 1ms



ANC 402

General Settings	Particulars
Password protection (YES/NO)	0000-9999
1. General Config.	
Line CT Primary	5A to 5000A in steps of 5A
Line CT Secondary	1A to 5A in steps of 1A
NCT Primary	1A to 5A in steps of 1A
NCT Secondary	1A to 5A in steps of 1A
Trip Circuit Supervision	En/Dis
Trip counter Reset	Reset/Discard
Post fault cycle	0 to 5 in steps of 1
Relay ID	1 to 255 in steps of 1
Baud Rate	4800-57600 in steps of 200
Set Date Time	(Yes/No) DD/MM/YY HH:MM:SS
Trip Relay Test	
2. IDMT OC Protection	
IDMT Curve Selection	1- Normal Inv. 2- Extremely Inv. 3- Very Inv. 4- Restricted Inv. 5- 3 Sec Delay 6- 1.3 Sec Delay 7- Long Time Delay
Trip Val (%)	5-200% in steps of 1%
TMS(Sec)	0.01-1.00 Sec in steps of 0.01 Sec
3. Current Unbalance	
Trip Val (%)	2.50 to 100% in steps of 0.5%
Trip Time(mSec)	0 to 1000mSec in steps of 1mSec
4. LBB	
LBB	EN/DIS
Trip Time(mSec)	50 to 5000ms in steps of 1ms



ANC 033

General Settings	Particulars
Password protection (YES/NO)	0000-9999
1. General Config.	
Line PT Primary	110 to 30000V in steps of 10V
UB PT Primary	110 to 30000V in steps of 10V
Trip counter Reset	Reset/Discard
Post fault cycle	0 to 5 in steps of 1
Relay ID	1 to 255 in steps of 1
Baud Rate	4800 to 57600 in steps of 200
Set Date Time	(Yes/No) DD/MM/YY HH:MM:SS
Trip Relay Test	
2. OV Protection	
Trip Val (%)	100 to 200% in steps of 1%
TMS (Sec)	0.01 to 1.00Sec in steps of 0.01 Sec
3. UV Protection	
UV	EN/DIS
Trip Val (%)	20 to 90% in steps of 1%
TMS (Sec)	0.01 to 1.00 Sec in steps of 0.01 Sec
4. Voltage Unbalance	
Trip Val (%)	5 to 90% in steps of 1%
Trip Time(Sec)	0 to 100Sec in steps of 0.1Sec
5. Time Delay Relay	
Delay Time(Min)	0 to 10Min in steps of 1 Min.
6. LBB	
LBB	EN/DIS
Trip Time(mSec)	50 to 5000ms in steps of 1ms



TB DETAILS

ANC 214

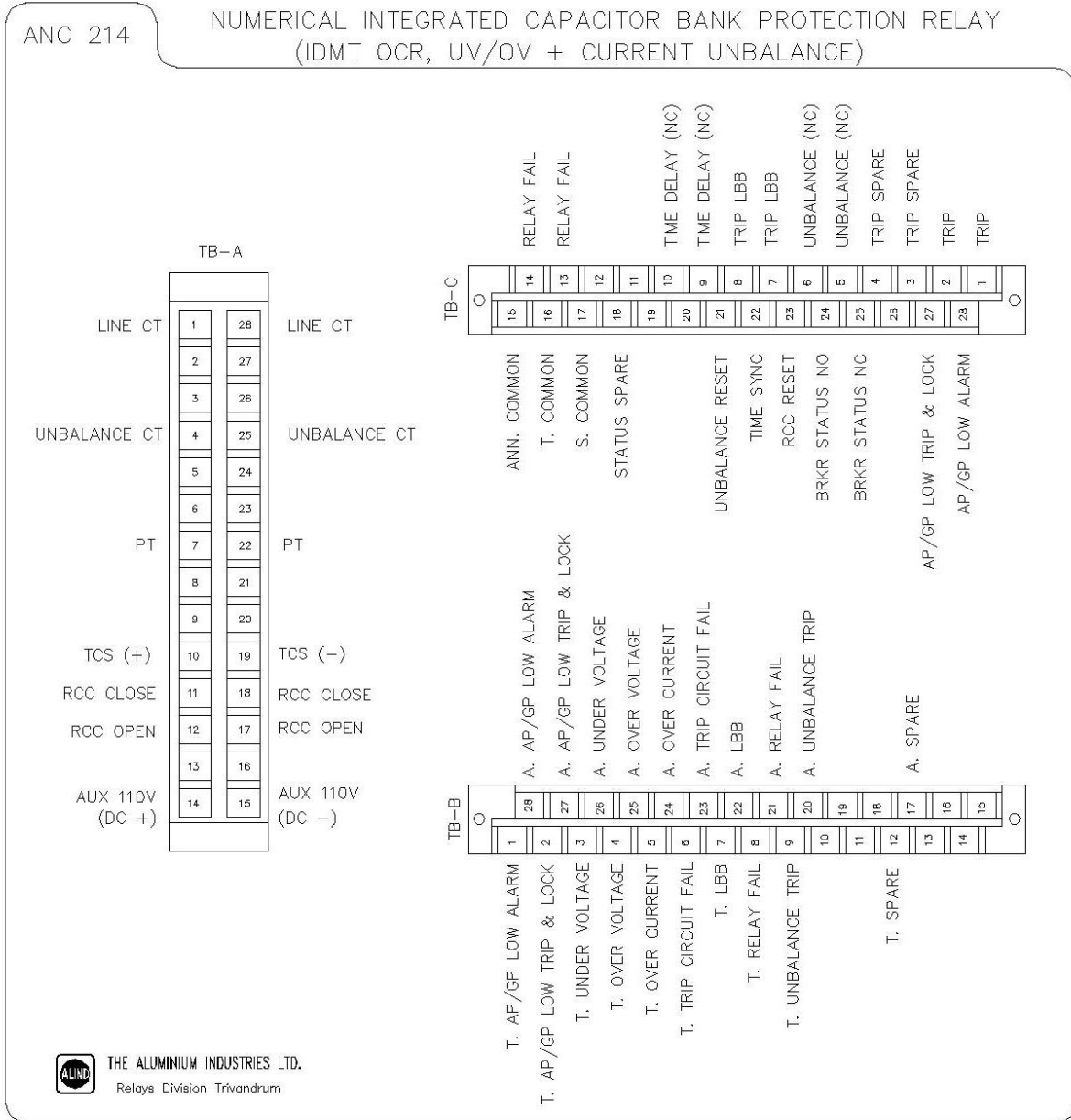

ANC 402

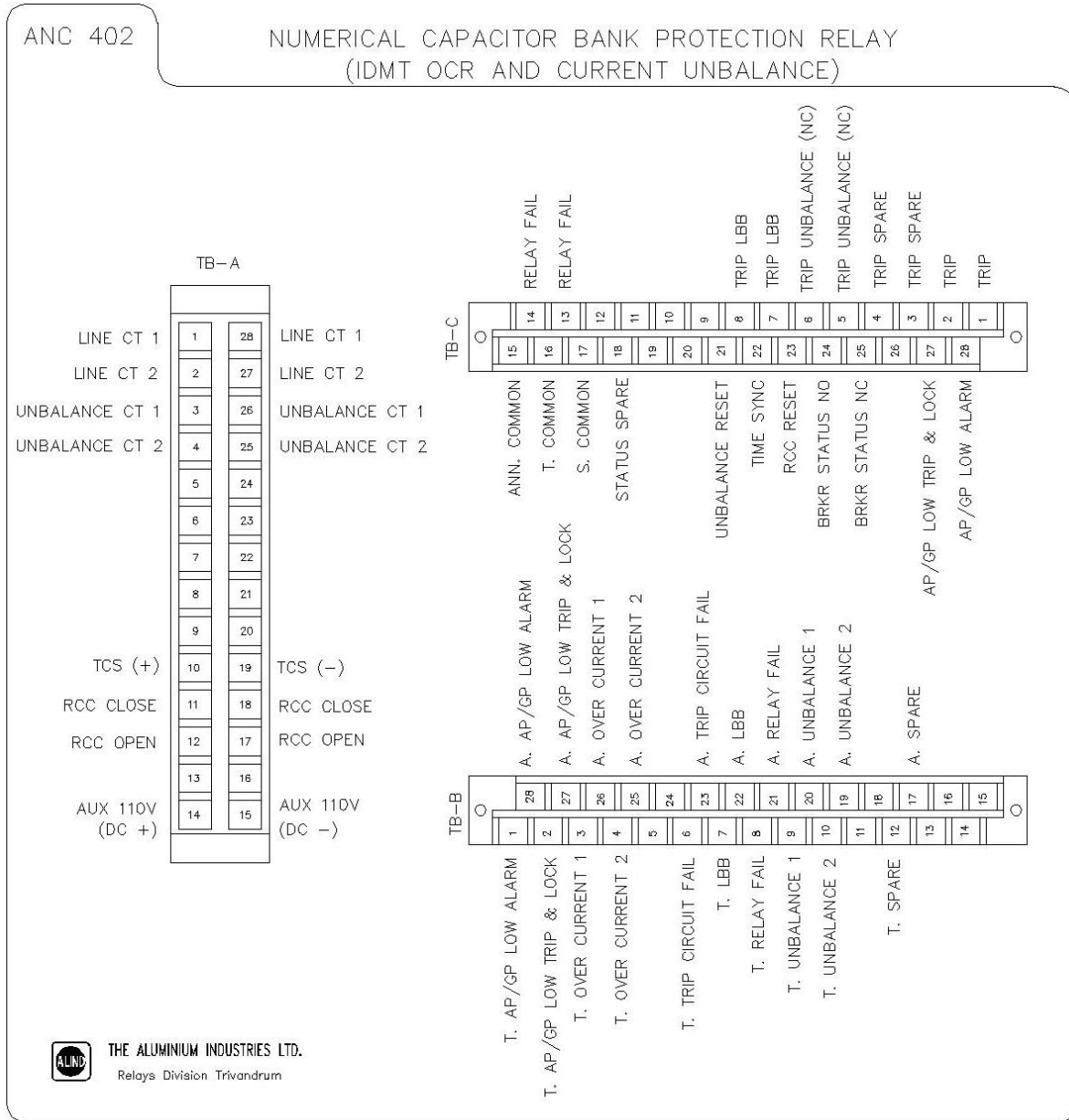

ANC 033

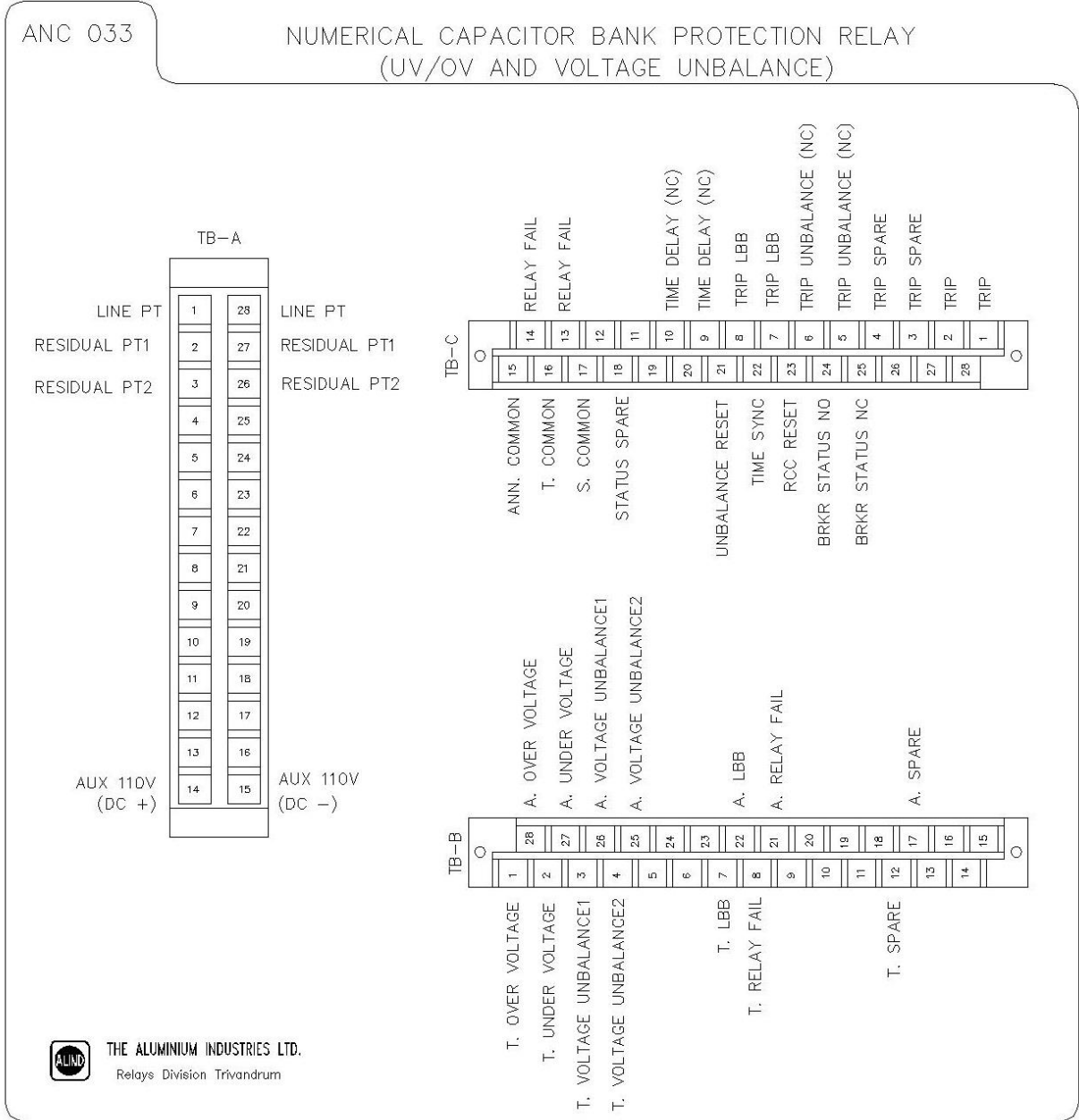

RELAY CONFORMING STANDARDS

The relay conforms to the following standards:

SI No.	Standards	Description
I.	IEC 60255-151	FUNCTIONAL REQUIREMENTS FOR OVER/UNDER CURRENT PROTECTION.
II.	IEC 60255-5	INSULATION COORDINATION OF MEASURING RELAYS AND PROTECTION EQUIPMENT- REQUIREMENTS AND TESTS.
III.	IEC 60255-1	MEASURING RELAYS AND PROTECTION EQUIPMENT- COMMON REQUIREMENTS.
IV.	IEC 60255-21-1	VIBRATION TESTS (SINUSODIAL)
V.	IEC 60255-21-2	SHOCK AND BUMP TESTS
VI.	IEC 60255-21-3	SEISMIC TESTS
VII.	IEC 60255-27	PRODUCT SAFETY REQUIREMENT.
VIII.	IEC 60255-26	ELECTROMAGNETIC COMPATIBILITY REQUIREMENT.
IX.	IEC 60529	DEGREES OF PROTECTION PROVIDED BY ENCLOSURES (IP CODE)
X.	IEC 61810-2	RELIABILITY.
XI.	IS 2705 (PART II, III&IV)	PROTECTIVE CURRENT TRANSFORMERS.
XII.	IS 3156 (PART II/III)	MEASURING/PROTECTIVE VOLTAGE TRANSFORMERS.
XIII.	IS 3231 (PART 1 TO 3)	ELECTRICAL RELAYS FOR POWER SYSTEM PROTECTION.
XIV.	IS 8686	STATIC PROTECTIVE RELAYS.
XV.	IEC 60068-2	ENVIRONMENTAL TESTS.
XVI.	IEC 60870-5-103	COMMUNICATION PROTOCOL



TROUBLESHOOTING



Under normal working conditions, the 'PROTECTION HEALTHY LED' provided in the front panel of the relay glows green. The same LED turns amber to recognize any fault inside the relay itself.

Following are certain guidelines for the relay to identify the nature of fault and necessary checking procedures to be adopted at site so that relay can be rectified suitably.

Sl. No.	Faults	Checks	Causes
1.	No power ON Indication or No display.	<ol style="list-style-type: none"> 1. Check the auxiliary DC supply to the relay rear terminals TB A-14: +110VDC TB A-15: -110VDC 2. Check the continuity of the output terminal, after disconnecting the wires. 	<ol style="list-style-type: none"> 1. Due to power supply failure, the LED turns off. The varistor may short circuited to protect internal circuitry on transients.
2.	Voltage Not reading/ Out of tolerance limit.	<ol style="list-style-type: none"> 1. Refer TB sticker for Voltage input 2. Check if the terminals of TB-A is connected properly or for any loose contact. 2. Check the continuity of the output terminal, after disconnecting the wires. <p>After checking of the above, measure the DC Voltages using calibrated Multi-meter. If not OK, intimate to works.</p>	<ol style="list-style-type: none"> 1. The varistor may short circuited to protect internal circuitry on transients.
3.	Relay Fail Indication	<ol style="list-style-type: none"> 1. Intimate to works. 2. Press H.RST key in the relay front panel. 	<ol style="list-style-type: none"> 1. Supply variation to internal PCB's. 2. DC supply fail.



**SCADA COMMUNICATION INTERFACE AS PER IEC
60870-5-103 PROTOCOL**

TYPE – ANC 214

**DESIGNED AS PER RDSO SPECIFICATION NO.
TI/SPC/PSI/PROTCT/7100 (07/2012)**



**ALUMINIUM INDUSTRIES LIMITED
RELAYS DIVISION**

OVERVIEW

IEC 60870-5-103 PROTOCOL

The IEC 60870-5-103 protocol is designed for use with the data transmission between IED's like protection equipment and control systems. The protocol defines application service data units which specify the message layout and contents, and describing the situations in which messages are sent. The companion standard IEC 60870-5-103 is derived from the IEC 60870-5 protocol standard definition and specifies a functional profile for basic tele control tasks. The IEC 60870-5 protocol stack is based on the reduced reference model called "Enhanced Performance Architecture" (EPA). This architecture includes only three layers of the ISO OSI model: the physical layer, link layer and application layer. Either a fiber optic system or copper wire based transmission system is used in this companion standard between the protection equipment and the control system.

The copper wire based transmission shall comply with the **EIA RS-485** standard. Due to the characteristics of the EIA RS-485 standard a maximum number of 32 units of load can be connected to one physical line.

1. TERMS, SERVICES AND DEFINITIONS

1.1 ADDRESS SETTING

IEC protocol is a multipoint protocol. This means that one master can communicate with multiple slaves on the same communication line. Due to this a given slave must have a unique id with which to address it – relay address. Relay address must lie in the range 1 to 254. Address 255 is reserved as a global broadcast address.

1.2 GENERAL INFORMATION

Messages representation is expressed with the associated:

- INFORMATION NUMBER: **INF**
- ASDU TYPE: **TYP**
- CAUSE OF TRANSMISSION: **COT**
- FUNCTION NUMBER: **FUN**.

1.3 ASDU (Application Service Data Units) Supported by the IED:

- Initialization (Reset/FCB)
- Time Synchronization
- Time Tagged Messages
- Spontaneous messages
- General Interrogation
- General command
- Cyclic measurements

STANDARD ASDUS IN MONITORING DIRECTION

#	DESIGNATION	SUPPORTED	REMARK
ASDU 1	Time-tagged message	YES	All available events and binary information with time stamp. Also the information from modules in additional module slot.
ASDU 2	Time-tagged message with relative time	YES	-
ASDU 3	Measurands I	NO	-
ASDU 4	Time-tagged measurands with relative time	YES	-
ASDU 5	Identification	YES	-
ASDU 6	Time synchronization	YES	-
ASDU 7	General Interrogation	YES	-
ASDU 8	General interrogation termination	YES	-
ASDU 9	Measurands II	YES	-
ASDU 10	Generic data	NO	-
ASDU 11	Generic identification	NO	-
ASDU 23	List of Recorded disturbances	YES	-
ASDU 26	Ready for transmission of disturbance data	YES	-
ASDU 27	Ready for transmission of channel	YES	-
ASDU 28	Ready for transmission of tags	YES	-
ASDU 29	Transmission of tags	YES	-
ASDU 30	Transmission of disturbance values	YES	-
ASDU 31	End of transmission	YES	-

STANDARD ASDUS IN CONTROL DIRECTION

#	DESIGNATION	SUPPORTED	REMARK
ASDU 6	Time synchronization	YES	-
ASDU 7	General interrogation	YES	-
ASDU 10	Generic data	NO	-
ASDU 20	General command	YES	-
ASDU 21	Generic command	NO	-
ASDU 24	Order for disturbance data transmission	YES	-
ASDU 25	Acknowledgement for disturbance data transmission	YES	-

1.4 INITIALIZATION

When the IED is connected to the communication system or if the communication parameters have been changed, a reset command is required to initialize the entire communications. A reset to the communication function is affected by means of a reset command from the control system. This is generally transmitted by the control system when:

- The control system is initialized
- The protection equipment does not respond during a certain period

This reset command does not affect the protection function, but only resets the communication part of the protection equipment. The reset command can be transmitted as

- Reset Frame Count Bit (FCB) or
- Reset Communication unit (CU)

In the case of reset FCB, the internal FCB bit in the protection equipment is set to '0'. Messages in the transmission buffer are not deleted.

In the case of CU, the messages in the transmission buffer are additionally deleted.

1.5 TIME SYNCHRONIZATION

Usually the time synchronize command is used to synchronize time of all secondary devices on a network. This command is also used to set the time of an individual secondary section. This command updates the current date and time from the master to slave.

1.6 TIME TAGGED MESSAGES

Two types of ASDU can be generated for events:

- ASDU 1: time-tagged message
- ASDU 2: time-tagged message with relative time

In the following list of processed events, FUNCTION NUMBERS (FUN) are used for Public range, respectively for current and voltage protections data.

1.7 SPONTANEOUS MESSAGES

These messages include a sub-assembly of the events, which are generated on the relay. The messages considered are concerning highest priority events. An event is always generated on the rising edge of the information; some can be generated also on falling edge.

In the list below (**Address Mapping**), events generated only on rising edge will be tagged with a ‘↑’.

1.8 GENERAL INTERROGATION

General interrogation is used to retrieve the state of certain events at the time of interrogation. A General Interrogation cycle is initiated by sending an initialization of General Interrogation ASDU of Type 7 to the address of the station to interrogate. The completion of a General Interrogation cycle will be signified by a General Interrogation Termination message.

1.9 GENERAL COMMAND

The Instruction/Command that is given to change the state of the IED through Master via ASDU 20, after executing one command, the relay sends an acknowledgement message, which contains the result of command execution. If a state change is the consequence of the command, it must be sent in an ASDU 1 with COT 1, 9. If the relay receives another command message from the master station before sending the Acknowledgement message, it will be discarded. Commands which are not processed by the relay are rejected with a negative acknowledgement message.

1.10 CYCLIC MEASUREMENTS

Measurands values are stored in lower levels of communication that is, Class 2 events, before polling by master station. In **ASDU 9** the following values are stored (with a rate such as: $2.4 * \text{rated value} = 4096$).

2. TMW TEST HARNESS

The **Communication Protocol Test Harness** is a Windows application that simulates a typical Master or Slave device. It can be configured through a Graphical User Interface (GUI) and/or scripts to provide automated testing or simulation of a device. Tasks such as polling, performing control operations, and setting input or output values are done through this test software.

ALIND has implemented the IEC 60870-5 Tele-control Companion Standard 103 in the **ANC 214** for communication with a controlling system. The IEC 60870-5 Tele-control Companion Standard TMW Test harness test set can be used as a communication protocol for exchanging information between Control Centre(s) (controlling station) and their substations (controlled station(s)). The information exchanged can be for status messages and commands.

3. LINK LAYER AND PHYSICAL CONNECTION

IEC 60870-5-2 offers a selection of link transmission procedures using a control field and the optional address field. Links between stations may be operated in either an unbalanced or a balanced transmission mode. Appropriate function codes for the control field are specified for both modes of operation. If the links from a central control station (controlling station) to several outstations (controlled stations) share a common physical channel, then these links must be operated in an unbalanced mode to avoid the possibility of more than one outstation attempting to transmit on the channel at the same time. The sequence in which the various outstations are granted access to transmit on the channel is then determined by an application layer procedure in the controlling station. The companion standard specifies whether an unbalanced or a balanced transmission mode is used, together with which link procedures (and corresponding link function codes) are to be used. The companion standard specifies an unambiguous address (number) for each link. Each address may be unique within a specific system, or it may be unique within a group of links sharing a common channel. The latter needs a smaller address field but requires the controlling station to map addresses by channel number.

The protocol uses frames and these frames contain octets that are transmitted as least significant first, without idle time. If transmission have been performed between Master and the Slave the slave will respond to the message with Link status Acknowledgement.

- **Rear serial port for SCADA Interface – EIA RS -485**

4. SYSTEM OR DEVICE CONFIGURATION

A Controlled station definition is used in this companion standard.

4.1 PHYSICAL LAYER

The physical layer defines the hardware-dependent specifications of the IEC 60870-5-103 communication interface.

4.1.2 ELECTRICAL INTERFACE

EIA RS-485

Note: EIA RS-485 standard defines unit loads so that 32 of them can be operated on one line.

4.1.3 TRANSMISSION SPEED

Supported Standard transmission speed;

9600 bit/s, 19200 bit/s and 57600 bit/s

4.2 LINK LAYER

The data link layer (link layer) defines the frame formats and the transmission procedures of the IEC communication.

4.3 APPLICATION LAYER

The application layer defines the information elements for structuring application data and the communication service functions.

4.4 TRANSMISSION MODE FOR APPLICATION DATA

Mode 1 (Least significant octet first), as defined in clause 4.10 of IEC 60870-5-4, is used exclusively in this companion standard.

4.5 COMMON ADDRESS OF ASDU

One octet is used in this companion standard.

4.6 INFORMATION OBJECT ADDRESS

Two octets are used in this companion standard and those were in Structured and Unstructured format.

4.7 CAUSE OF TRANSMISSION

One octet is used in this companion standard.

4.8 LENGTH OF APDU

(System-specific parameter, specify the maximum length of the APDU per system).

The maximum length of the APDU is 253 (default). The maximum length may be reduced per system.

5. PROTOCOL MAPPING

SYSTEM FUNCTIONS IN MONITOR DIRECTIONS

DESCRIPTION	GI	ASDU TYPE	FUN	INF	COT	COM
End of general interrogation	-	8	255	0	10	GLB
Time synchronization	-	6	255	0	8	GLB
Reset FCB	-	5	180	2	3	According to main FUN
Reset CU	-	5	180	3	4	According to main FUN
Reset CU/Start/Restart	-	5	180	4	5	According to main FUN

STATUS INDICATION IN MONITOR DIRECTION

DESCRIPTION	GI	ASDU TYPE	FUN	INF	COT	COM
Protection Healthy/Active	-	1	180	18	1	↑
LED Reset	-	1	180	19	1	↑
Local Parameter Settings (Change)	-	1	180	22	1	↑
AP/GP Low Alarm	X	1	180	29	1,9	↑↓
AP/GP Trip & Lock	X	1	180	30	1,9	↑↓
Spare	X	1	180	26	1,9	↑↓
CB NC (FDR CB OPEN)	X	1	180	136	1,9	↑↓
CB NO (FDR CB CLOSE)	X	1	180	137	1,9	↑↓
TDR (Time Delay Relay)	X	1	180	34	1,9	↑↓
Relay Fail	-	1	180	40	1	↑

SUPERVISION INDICATIONS IN MONITOR DIRECTION

DESCRIPTION	GI	ASDU TYPE	FUN	INF	COT	COM
Trip circuit supervision	X	1	180	36	1,9	↑↓

FAULT INDICATION IN (MONITOR DIRECTIONS)

DESCRIPTION	GI	ASDU TYPE	FUN	INF	COT	COM
Breaker Failure (LBB)	X	2	180	85	1,9	↑↓
Start/pickup IDMT	X	2	180	64	1,9	↑↓
Start/pickup Over Voltage	X	2	180	65	1,9	↑↓
Start/pickup Under Voltage	X	2	180	66	1,9	↑↓
Start/pickup Unbalance	X	2	180	63	1,9	↑↓
IDMT Trip	-	2	180	103	1	↑↓
Under Voltage Trip	-	2	180	100	1	↑↓
Over Voltage Trip	-	2	180	101	1	↑↓
Unbalance Trip	-	2	180	146	1	↑↓

MEASURAND IN MONITOR DIRECTION

DESCRIPTION	GI	ASDU TYPE	FUN	INF	COT	COM
Measurand supervision Line CT	-	9	180	148	2	↑↓
Measurand supervision Unbalance CT	-	9	180	148	2	↑↓
Measurand supervision VT	-	9	180	148	2	↑↓

TIME TAGED MEASURAND IN MONITOR DIRECTIONS

DESCRIPTION	GI	ASDU TYPE	FUN	INF	COT	COM
Fault Current – I	-	4	180	141	1	↑↓
Unbalance Fault Current – I	-	4	180	142	1	↑↓
Fault Voltage – V	-	4	180	151	1	↑↓

STANDARD INFORMATION NUMBERS IN CONTROL DIRECTION**SYSTEM FUNCTIONS IN CONTROL DIRECTION**

DESCRIPTION	GI	ASDU TYPE	FUN	INF	COT	COM
Initiation of general interrogation	-	7	255	0	9	GLB
Time Synchronization	-	6	255	0	8	GLB

GENERAL COMMANDS IN CONTROL DIRECTION

DESCRIPTION	GI	ASDU TYPE	FUN	INF	COT	COM
LED RESET	-	20	180	19	20	↑ (PULSE)
Unbalance Reset	-	20	180	35	20	↑ (PULSE)
CB Open	-	20	180	124	20	↑ (PULSE)
CB Close	-	20	180	125	20	↑ (PULSE)

6. DISTURBANCE DATA RECORDER

In digital protection equipment, analogue currents and voltages are sampled with given sampling rates, to be processed by the protection functions. Additionally, these samples may be stored in order to be a basis for a disturbance recorder function.

In the protection equipment, disturbance recording includes:

- Analogue values (disturbance values), digitally coded as currents IL1, IL2, IL3, IN and voltages VL1, VL2, VL3, VEN;
- Binary values (indications), recorded as tags, for example start/pick-up and trip indications.

6.1 DISTURBANCE RECORDER FILES TRANSFER/DISTURBANCE RECORDINGS

- The transfer functionality is based on the Disturbance recorder function. The analog and binary signals recorded will be reported to the master by polling. The two hundred disturbances (customized) that are recorded are available for transfer to the master.

- The data function blocks include the function type and the information number for each channel. The analog channels, that are reported, are those connected to the disturbance function blocks. The two hundred disturbance are belongs to the private range because of customization and transfers the multiples of 20 latest list of disturbance records.

- In Disturbance recordings the following elements are used in the ASDUs (Application Service Data Units) defined in the standard. Analog signals, 4-channels (MAX): the channel number for each channel has to be specified. Channels used in the public range are 1 to 8 i.e.

6.2 ACTUAL CHANNEL INFO

CHANNEL(ACC)		
FUN	ACC	
FUN	1	Ir
FUN	2	Iy
FUN	3	Ib
FUN	4	Ie / I
FUN	5	V1
FUN	6	V2
FUN	7	V3
FUN	8	Vn/V4

#Some Relays channels were customized in-order to meet compatibility with Master application software

- After analog channel transmission the Tags (digital channels) are transmitted through another ASDU, Tags are the digital signals, the IED (Protection Equipment) contains a maximum of 32 digital Tags, and the information element includes Function type, Information number, and Fault number along with the tag position.

6.3 DEVIATIONS FROM THE STANDARD

Information sent in the disturbance upload is specified by the standard; however, some of the information handlings are customized in-order to meet customer requirements. This section describes all data that is not exactly as specified in the standard.

LIST OF STANDARD ASDU IN DISTURBANCE RECORDING

#	DESIGNATION	SUPPORTED	REMARK
ASDU 7	General Interrogation	Yes	-
ASDU 8	General interrogation termination	Yes	-
ASDU 23	List of recorded disturbance	Yes	-
ASDU 26	Ready for transmission of disturbance data	Yes	-
ASDU 27	Ready for transmission of channel	Yes	-
ASDU 28	Ready for transmission of tags	Yes	-
ASDU 29	Transmission of tags	Yes	-
ASDU 30	Transmission of disturbance values	Yes	-
ASDU 31	End of transmission	Yes	-

STANDARD ASDUS IN CONTROL DIRECTION

#	DESIGNATION	SUPPORTED	REMARK
ASDU 24	Order for disturbance data transmission	Yes	-
ASDU 25	Acknowledgement for disturbance data transmission	Yes	-

6.4 GENERIC DISTURBANCE ORDER COMMAND.

Generic disturbance order command allows the selection of fault, function type of specific relays and most importantly it consists of Type of order command (TOO).The TOO command has specific task like it can poll different ASDU's with a positive or negative acknowledgement.

6.5 TOO (TYPE OF ORDER)

TOO specifies the type of order, for example selection, request, and abort of transmission of disturbance data, channels, tags, and list of recorded disturbances.

7.0 ADVANCED FEATURES ADDED

1. DR PHYSICAL ERASE

7.1 DR PHYSICAL ERASE

Up-to two hundred disturbances are made available in Relay, due to certain storage limitation, once a DR is polled and saved, the DR will be erased permanently and the same will access directly through Alind relay soft. Software

8. ANALOG CHANNEL INFORMATION IN ANC 214

ANC 214		
FUN	ACC	PARAMETER
180	1	I
180	2	In
180	3	x
180	4	x
180	5	V
180	6	x
180	7	x
180	8	x

9. DIGITAL CHANNEL (TAGS) INFORMATION IN ANC 214

ANC 214			
TAG POSITION	FUN/INF NUMBER	SEMANTICS ACCORDING TO TAG POSITION	INPUT/OUTPUT
0	180/84	GENERAL PICKUP	OUTPUT
1	180/68	GENERAL TRIP	OUTPUT
2	180/103	IDMT TRIP	OUTPUT
3	180/100	UNDER VOLTAGE TRIP	OUTPUT
4	180/101	OVER VOLTAGE TRIP	OUTPUT
5	180/146	UNBALANCE TRIP	OUTPUT
6	180/85	BREAKER FAILURE	OUTPUT
6	180/27	UNBALANCE RESET - LOG I/P - 1	INPUT
7	255/0	TIME SYNC - LOG I/P - 2	INPUT
8	180/19	LED RESET - LOG I/P - 3	INPUT
9	180/136	CB NC (OPEN) - LOG I/P - 4	INPUT
10	180/137	CB NO (CLOSE) - LOG I/P - 5	INPUT
11	180/30	AP/GP LOW TRIP & LOCK - LOG I/P - 6	INPUT
12	180/29	AP/GP LOW ALARM - LOG I/P - 7	INPUT
13	180/34	TDR - LOG I/P - 8	INPUT
14	180/36	TRIP CIRCUIT SUPERVISION - LOG I/P - 9	INPUT

**SCADA COMMUNICATION INTERFACE AS PER IEC
60870-5-103 PROTOCOL**

TYPE – ANZ 214

**DESIGNED AS PER RDSO SPECIFICATION NO.
TI/SPC/PSI/PROTCT/7100 (07/2012)**



**ALUMINIUM INDUSTRIES LIMITED
RELAYS DIVISION**

OVERVIEW

IEC 60870-5-103 PROTOCOL

The IEC 60870-5-103 protocol is designed for use with the data transmission between IED's like protection equipment and control systems. The protocol defines application service data units which specify the message layout and contents, and describing the situations in which messages are sent. The companion standard IEC 60870-5-103 is derived from the IEC 60870-5 protocol standard definition and specifies a functional profile for basic tele control tasks. The IEC 60870-5 protocol stack is based on the reduced reference model called "Enhanced Performance Architecture" (EPA). This architecture includes only three layers of the ISO OSI model: the physical layer, link layer and application layer. Either a fiber optic system or copper wire based transmission system is used in this companion standard between the protection equipment and the control system.

The copper wire based transmission shall comply with the **EIA RS-485** standard. Due to the characteristics of the EIA RS-485 standard a maximum number of 32 units of load can be connected to one physical line.

1. TERMS, SERVICES AND DEFINITIONS

1.1 ADDRESS SETTING

IEC protocol is a multipoint protocol. This means that one master can communicate with multiple slaves on the same communication line. Due to this a given slave must have a unique id with which to address it – relay address. Relay address must lie in the range 1 to 254. Address 255 is reserved as a global broadcast address.

1.2 GENERAL INFORMATION

Messages representation is expressed with the associated:

- INFORMATION NUMBER: **INF**
- ASDU TYPE: **TYP**
- CAUSE OF TRANSMISSION: **COT**
- FUNCTION NUMBER: **FUN**.

1.3 ASDU (Application Service Data Units) Supported by the IED:

- Initialization (Reset/FCB)
- Time Synchronization
- Time Tagged Messages
- Spontaneous messages
- General Interrogation
- General command
- Cyclic measurements

STANDARD ASDUS IN MONITORING DIRECTION

#	DESIGNATION	SUPPORTED	REMARK
ASDU 1	Time-tagged message	YES	All available events and binary information with time stamp. Also the information from modules in additional module slot.
ASDU 2	Time-tagged message with relative time	YES	-
ASDU 3	Measurands I	NO	-
ASDU 4	Time-tagged measurands with relative time	YES	-
ASDU 5	Identification	YES	-
ASDU 6	Time synchronization	YES	-
ASDU 7	General Interrogation	YES	-
ASDU 8	General interrogation termination	YES	-
ASDU 9	Measurands II	YES	-
ASDU 10	Generic data	NO	-
ASDU 11	Generic identification	NO	-
ASDU 23	List of Recorded disturbances	YES	-
ASDU 26	Ready for transmission of disturbance data	YES	-
ASDU 27	Ready for transmission of channel	YES	-
ASDU 28	Ready for transmission of tags	YES	-
ASDU 29	Transmission of tags	YES	-
ASDU 30	Transmission of disturbance values	YES	-
ASDU 31	End of transmission	YES	-

STANDARD ASDUS IN CONTROL DIRECTION

#	DESIGNATION	SUPPORTED	REMARK
ASDU 6	Time synchronization	YES	-
ASDU 7	General interrogation	YES	-
ASDU 10	Generic data	NO	-
ASDU 20	General command	YES	-
ASDU 21	Generic command	NO	-
ASDU 24	Order for disturbance data transmission	YES	-
ASDU 25	Acknowledgement for disturbance data transmission	YES	-

1.4 INITIALIZATION

When the IED is connected to the communication system or if the communication parameters have been changed, a reset command is required to initialize the entire communications. A reset to the communication function is affected by means of a reset command from the control system. This is generally transmitted by the control system when:

- The control system is initialized
- The protection equipment does not respond during a certain period

This reset command does not affect the protection function, but only resets the communication part of the protection equipment. The reset command can be transmitted as

- Reset Frame Count Bit (FCB) or
- Reset Communication unit (CU)

In the case of reset FCB, the internal FCB bit in the protection equipment is set to '0'. Messages in the transmission buffer are not deleted.

In the case of CU, the messages in the transmission buffer are additionally deleted.

1.5 TIME SYNCHRONIZATION

Usually the time synchronize command is used to synchronize time of all secondary devices on a network. This command is also used to set the time of an individual secondary section. This command updates the current date and time from the master to slave.

1.6 TIME TAGGED MESSAGES

Two types of ASDU can be generated for events:

- ASDU 1: time-tagged message
- ASDU 2: time-tagged message with relative time

In the following list of processed events, FUNCTION NUMBERS (FUN) are used for Public range, respectively for current and voltage protections data.

1.7 SPONTANEOUS MESSAGES

These messages include a sub-assembly of the events, which are generated on the relay. The messages considered are concerning highest priority events. An event is always generated on the rising edge of the information; some can be generated also on falling edge.

In the list below (**Address Mapping**), events generated only on rising edge will be tagged with a ‘↑’.

1.8 GENERAL INTERROGATION

General interrogation is used to retrieve the state of certain events at the time of interrogation. A General Interrogation cycle is initiated by sending an initialization of General Interrogation ASDU of Type 7 to the address of the station to interrogate. The completion of a General Interrogation cycle will be signified by a General Interrogation Termination message.

1.9 GENERAL COMMAND

The Instruction/Command that is given to change the state of the IED through Master via ASDU 20, after executing one command, the relay sends an acknowledgement message, which contains the result of command execution. If a state change is the consequence of the command, it must be sent in an ASDU 1 with COT 1, 9. If the relay receives another command message from the master station before sending the Acknowledgement message, it will be discarded. Commands which are not processed by the relay are rejected with a negative acknowledgement message.

1.10 CYCLIC MEASUREMENTS

Measurands values are stored in lower levels of communication that is, Class 2 events, before polling by master station. In **ASDU 9** the following values are stored (with a rate such as: $2.4 * \text{rated value} = 4096$).

2. TMW TEST HARNESS

The **Communication Protocol Test Harness** is a Windows application that simulates a typical Master or Slave device. It can be configured through a Graphical User Interface (GUI) and/or scripts to provide automated testing or simulation of a device. Tasks such as polling, performing control operations, and setting input or output values are done through this test software.

ALIND has implemented the IEC 60870-5 Tele-control Companion Standard 103 in the **ANC 402** for communication with a controlling system. The IEC 60870-5 Tele-control Companion Standard TMW Test harness test set can be used as a communication protocol for exchanging information between Control Centre(s) (controlling station) and their substations (controlled station(s)). The information exchanged can be for status messages and commands.

3. LINK LAYER AND PHYSICAL CONNECTION

IEC 60870-5-2 offers a selection of link transmission procedures using a control field and the optional address field. Links between stations may be operated in either an unbalanced or a balanced transmission mode. Appropriate function codes for the control field are specified for both modes of operation. If the links from a central control station (controlling station) to several outstations (controlled stations) share a common physical channel, then these links must be operated in an unbalanced mode to avoid the possibility of more than one outstation attempting to transmit on the channel at the same time. The sequence in which the various outstations are granted access to transmit on the channel is then determined by an application layer procedure in the controlling station. The companion standard specifies whether an unbalanced or a balanced transmission mode is used, together with which link procedures (and corresponding link function codes) are to be used. The companion standard specifies an unambiguous address (number) for each link. Each address may be unique within a specific system, or it may be unique within a group of links sharing a common channel. The latter needs a smaller address field but requires the controlling station to map addresses by channel number.

The protocol uses frames and these frames contain octets that are transmitted as least significant first, without idle time. If transmissions have been performed between Master and the Slave the slave will respond to the message with Link status Acknowledgement.

- **Rear serial port for SCADA Interface – EIA RS -485**

4. SYSTEM OR DEVICE CONFIGURATION

A Controlled station definition is used in this companion standard.

4.1 PHYSICAL LAYER

The physical layer defines the hardware-dependent specifications of the IEC 60870-5-103 communication interface.

4.1.2 ELECTRICAL INTERFACE

EIA RS-485

Note: EIA RS-485 standard defines unit loads so that 32 of them can be operated on one line.

4.1.3 TRANSMISSION SPEED

Supported Standard transmission speed;

9600 bit/s, 19200 bit/s and 57600 bit/s

4.2 LINK LAYER

The data link layer (link layer) defines the frame formats and the transmission procedures of the IEC communication.

4.3 APPLICATION LAYER

The application layer defines the information elements for structuring application data and the communication service functions.

4.4 TRANSMISSION MODE FOR APPLICATION DATA

Mode 1 (Least significant octet first), as defined in clause 4.10 of IEC 60870-5-4, is used exclusively in this companion standard.

4.5 COMMON ADDRESS OF ASDU

One octet is used in this companion standard.

4.6 INFORMATION OBJECT ADDRESS

Two octets are used in this companion standard and those were in Structured and Unstructured format.

4.7 CAUSE OF TRANSMISSION

One octet is used in this companion standard.

4.8 LENGTH OF APDU

(System-specific parameter, specify the maximum length of the APDU per system).

The maximum length of the APDU is 253 (default). The maximum length may be reduced per system.

5. PROTOCOL MAPPING

SYSTEM FUNCTIONS IN MONITOR DIRECTIONS

DESCRIPTION	GI	ASDU TYPE	FUN	INF	COT	COM
End of general interrogation	-	8	255	0	10	GLB
Time synchronization	-	6	255	0	8	GLB
Reset FCB	-	5	180	2	3	According to main FUN
Reset CU	-	5	180	3	4	According to main FUN
Reset CU/Start/Restart	-	5	180	4	5	According to main FUN

STATUS INDICATION IN MONITOR DIRECTION

DESCRIPTION	GI	ASDU TYPE	FUN	INF	COT	COM
Protection Healthy/Active	-	1	180	18	1	↑
LED Reset	-	1	180	19	1	↑
Local Parameter Settings (Change)	-	1	180	22	1	↑
AP/GP Low Alarm	X	1	180	29	1,9	↑↓
AP/GP Trip & Lock	X	1	180	30	1,9	↑↓
CB NC (FDR CB OPEN)	X	1	180	136	1,9	↑↓
CB NO (FDR CB CLOSE)	X	1	180	137	1,9	↑↓
RCC Unbalance Reset	-	1	180	27	1	↑
Relay Fail	-	1	180	40	1	↑

SUPERVISION INDICATIONS IN MONITOR DIRECTION

DESCRIPTION	GI	ASDU TYPE	FUN	INF	COT	COM
Trip circuit supervision	X	1	180	36	1,9	↑↓
VT Fuse failure (ALARM)	X	1	180	26	1,9	↑↓

FAULT INDICATION IN (MONITOR DIRECTIONS)

DESCRIPTION	GI	ASDU TYPE	FUN	INF	COT	COM
Breaker Failure (LBB)	X	2	180	85	1,9	↑↓
Start/pickup IDMT – 1	X	2	180	64	1,9	↑↓
Start/pickup IDMT – 2	X	2	180	65	1,9	↑↓
Start/pickup Unbalance CT – 1	X	2	180	66	1,9	↑↓
Start/pickup Unbalance CT – 2	X	2	180	67	1,9	↑↓
IDMT Trip – 1	-	2	180	94	1	↑↓
IDMT Trip – 2	-	2	180	102	1	↑↓
Unbalance Trip – 1	-	2	180	146	1	↑↓
Unbalance Trip – 2	-	2	180	147	1	↑↓

MEASURAND IN MONITOR DIRECTION

DESCRIPTION	GI	ASDU TYPE	FUN	INF	COT	COM
Measurand supervision I – Line CT – 1	-	9	180	148	2	↑↓
Measurand supervision I – Line CT – 2	-	9	180	148	2	↑↓
Measurand supervision I – Unbalance CT – 1	-	9	180	148	2	↑↓
Measurand supervision I – Unbalance CT – 1	-	9	180	148	2	↑↓

TIME TAGED MEASURAND IN MONITOR DIRECTIONS

DESCRIPTION	GI	ASDU TYPE	FUN	INF	COT	COM
Fault Current – I1	-	4	180	141	1	↑↓
Fault Current – I2	-	4	180	142	1	↑↓
Fault Current – In1	-	4	180	143	1	↑↓
Fault Current – In2	-	4	180	144	1	↑↓

STANDARD INFORMATION NUMBERS IN CONTROL DIRECTION**SYSTEM FUNCTIONS IN CONTROL DIRECTION**

DESCRIPTION	GI	ASDU TYPE	FUN	INF	COT	COM
Initiation of general interrogation	-	7	255	0	9	GLB
Time Synchronization	-	6	255	0	8	GLB

GENERAL COMMANDS IN CONTROL DIRECTION

DESCRIPTION	GI	ASDU TYPE	FUN	INF	COT	COM
LED (RCC) RESET	-	20	180	19	20	↑ (PULSE)
CB (O/o Open)	-	20	180	124	20	↑ (PULSE)
CB (C/c Close)	-	20	180	125	20	↑ (PULSE)
Unbalance (RCC) Reset	-	20	180	35	20	↑ (PULSE)

6. DISTURBANCE DATA RECORDER

In digital protection equipment, analogue currents and voltages are sampled with given sampling rates, to be processed by the protection functions. Additionally, these samples may be stored in order to be a basis for a disturbance recorder function.

In the protection equipment, disturbance recording includes:

- Analogue values (disturbance values), digitally coded as currents IL1, IL2, IL3, IN and voltages VL1, VL2, VL3, VEN;
- Binary values (indications), recorded as tags, for example start/pick-up and trip indications.

6.1 DISTURBANCE RECORDER FILES TRANSFER/DISTURBANCE RECORDINGS

- The transfer functionality is based on the Disturbance recorder function. The analog and binary signals recorded will be reported to the master by polling. The two hundred disturbances (customized) that are recorded are available for transfer to the master.

- The data function blocks include the function type and the information number for each channel. The analog channels, that are reported, are those connected to the disturbance function blocks. The two hundred disturbance are belongs to the private range because of customization and transfers the multiples of 20 latest list of disturbance records.

- In Disturbance recordings the following elements are used in the ASDUs (Application Service Data Units) defined in the standard. Analoge signals, 4-channels (MAX): the channel number for each channel has to be specified. Channels used in the public range are 1 to 8 i.e.

6.2 ACTUAL CHANNEL INFO

CHANNEL(ACC)		
FUN	ACC	
FUN	1	Ir
FUN	2	Iy
FUN	3	Ib
FUN	4	Ie / I
FUN	5	V1
FUN	6	V2
FUN	7	V3
FUN	8	Vn/V4

#Some Relays channels were customized in-order to meet compatibility with Master application software

- After analog channel transmission the Tags (digital channels) are transmitted through another ASDU, Tags are the digital signals, the IED (Protection Equipment) contains a maximum of 32 digital Tags, and the information element includes Function type, Information number, and Fault number along with the tag position.

6.3 DEVIATIONS FROM THE STANDARD

Information sent in the disturbance upload is specified by the standard; however, some of the information handlings are customized in-order to meet customer requirements. This section describes all data that is not exactly as specified in the standard.

LIST OF STANDARD ASDU IN DISTURBANCE RECORDING

#	DESIGNATION	SUPPORTED	REMARK
ASDU 7	General Interrogation	Yes	-
ASDU 8	General interrogation termination	Yes	-
ASDU 23	List of recorded disturbance	Yes	-
ASDU 26	Ready for transmission of disturbance data	Yes	-
ASDU 27	Ready for transmission of channel	Yes	-
ASDU 28	Ready for transmission of tags	Yes	-
ASDU 29	Transmission of tags	Yes	-
ASDU 30	Transmission of disturbance values	Yes	-
ASDU 31	End of transmission	Yes	-

STANDARD ASDUS IN CONTROL DIRECTION

#	DESIGNATION	SUPPORTED	REMARK
ASDU 24	Order for disturbance data transmission	Yes	-
ASDU 25	Acknowledgement for disturbance data transmission	Yes	-

6.4 GENERIC DISTURBANCE ORDER COMMAND.

Generic disturbance order command allows the selection of fault, function type of specific relays and most importantly it consists of Type of order command (TOO).The TOO command has specific task like it can poll different ASDU's with a positive or negative acknowledgement.

6.5 TOO (TYPE OF ORDER)

TOO specifies the type of order, for example selection, request, and abort of transmission of disturbance data, channels, tags, and list of recorded disturbances. The following ranges of TOO are used with the different ASDUs:

7. ANALOG CHANNEL INFORMATION IN ANC 402

ANC 402		
FUN	ACC	PARAMETER
180	1	I – 1
180	2	I – 2
180	3	In – 1
180	4	In – 2
180	5	x
180	6	x
180	7	x
180	8	x

8. DIGITAL CHANNEL (TAGS) INFORMATION IN ANC 402

ANC 402			
TAG POSITION	FUN/INF NUMBER	SEMANTICS ACCORDING TO TAG POSITION	INPUT/OUTPUT
0	180/84	GENERAL PICKUP	OUTPUT
1	180/68	GENERAL TRIP	OUTPUT
2	180/94	IDMT – 1 TRIP	OUTPUT
3	180/102	IDMT – 2 TRIP	OUTPUT
4	180/146	Unbalance – 1 TRIP	OUTPUT
5	180/147	Unbalance – 2 TRIP	OUTPUT
6	180/85	BREAKER FAILURE	OUTPUT
7	180/27	Unbalance (RCC) – Reset – LOG I/P – 1	INPUT
8	255/0	TIME SYNC – LOG I/P – 2	INPUT
9	180/19	LED (RCC) RESET – LOG I/P – 3	INPUT
10	180/136	CB NC (OPEN) – LOG I/P – 4	INPUT
11	180/137	CB NO (CLOSE) – LOG I/P – 5	INPUT
12	180/30	AP/GP LOW TRIP & LOCK - LOG I/P - 6	INPUT
13	180/29	AP/GP LOW ALARM – LOG I/P – 7	INPUT
14	180/36	TRIP CIRCUIT SUPERVISION – LOG I/P – 8	INPUT

TEST REPORT



TEST DETAILS**Relay characteristics & Operating Value Test****Operating Value Test for IDMT OCR**

IDMT setting (%)	Operating Value (A)	Drop off value (A)	Drop off / pick up (%)
20% = 1.0A			
40% = 2.0A			
80% = 4.0A			
100% = 5.0A			

Allowable tolerance limit in operating value is $\pm 5\%$

Current unbalance protection

Current Unbalance Setting (%)	Operating Value (A)
10% = 0.10A	
30% = 0.30A	
50% = 0.50A	
100% = 1.0A	

Allowable tolerance limit in operating value is $\pm 5\%$

Operating Value Test for Under voltage

Under Voltage setting (%)	Operating Value (V)	Drop Off value (V)	Pick up / Drop off (%)
20% = 22V			
30% = 33V			
50% = 55V			
60% = 66V			

Allowable tolerance limit in operating value is $\pm 5\%$

Operating Value Test for over voltage

Over voltage setting (%)	Operating Value (V)	Drop Off value (V)	Drop off / Pick up (%)
100%=110V			
110%=121V			
130%=143V			

Allowable tolerance limit in operating value is $\pm 5\%$



Operating Time Measuring Test**IDMT PROTECTION**

IDMT setting (%)	TMS setting	Current Injected (A)	Expected Time from curve (Sec)	Observed Time (Sec)
20%	0.1	4A	0.50	
20%	0.1	10A	0.30	
20%	0.1	20A	0.23	
20%	0.5	10A	1.50	
20%	1	10A	3.00	
100%	1	20A	4.98	

Allowable tolerance limit in operating time is $\pm 5\%$

CURRENT UNBALANCE PROTECTION

Current unbalance setting (%)	Current Injected (A)	Delay (ms)	Observed Time (ms)
40%	1A	100	
40%	1A	150	
80%	2A	250	

Allowable tolerance limit in operating time is $\pm 5\%$

UNDER VOLTAGE PROTECTION

PSM Setting (%)	TMS setting	Applied voltage (V)	Expected Time from curve (Sec)	Observed Time (Sec)
90%	0.1	88	2.353	
90%	0.5	44	3.445	
90%	1	22	5.680	
60%	1	0	5.00	

Allowable tolerance limit in operating time is $\pm 5\%$



OVER VOLTAGE PROTECTION

PSM Setting (%)	TMS setting	Applied voltage (V)	Expected Time from curve (Sec)	Observed Time (Sec)
100%	0.1	115	6.37	
100%	0.5	115	31.86	
100%	0.5	121	14.86	

Allowable tolerance limit in operating time is $\pm 5\%$

TIME DELAY RELAY

TDR setting (Min)	TDR observed (Min)
1	
2	
5	

Allowable tolerance limit in operating time is $\pm 5\%$

Local Breaker Backup (LBB) Trip:

Settings: OCR setting = 50%

LBB time setting	Current Injected (A)	Breaker status	LBB Status	LBB + IDMT time (ms)
200ms	15A	Not operated	Operated	
		Operated	Not operated	
500ms	10A	Not operated	Operated	
		Operated	Not operated	

Allowable tolerance limit in operating time is $\pm 5\%$

Status Verification

Status	Status input	Output contact verification
AP/GP LOW ALARM	Short TB-C 17 & 28	
AP/GP TRIP & LOCK	Short TB-C 17 & 27	



ALUMINIUM INDUSTRIES LTD



Relays division
Kavinpuram, Vilappilsala (P.O)
Thiruvananthapuram
Kerala
India-695 573
Ph: 0471-2379704, 2379503
Email: alindrelays@yahoo.com

Subject to change without notice

Publishing: 08/2016
Issue: 1